

BXUV.D743

Design/System/Construction/Assembly Usage Disclaimer

- Authorities Having Jurisdiction should be consulted in all cases as to the particular requirements covering the installation and use of UL Certified products, equipment, system, devices, and materials.
- Authorities Having Jurisdiction should be consulted before construction.
- Fire resistance assemblies and products are developed by the design submitter and have been investigated by UL for compliance with applicable requirements. The published information cannot always address every construction nuance encountered in the field.
- When field issues arise, it is recommended the first contact for assistance be the technical service staff provided by the product manufacturer noted for the design. Users of fire resistance assemblies are advised to consult the general Guide Information for each product category and each group of assemblies. The Guide Information includes specifics concerning alternate materials and alternate methods of construction.
- Only products which bear UL's Mark are considered Certified.

BXUV - Fire Resistance Ratings - ANSI/UL 263 Certified for United States

BXUV7 - Fire Resistance Ratings - CAN/ULC-S101 Certified for Canada

See General Information for Fire-resistance Ratings - ANSI/UL 263 Certified for United States
Design Criteria and Allowable Variances

See General Information for Fire Resistance Ratings - CAN/ULC-S101 Certified for Canada
Design Criteria and Allowable Variances

Design No. D743

October 04, 2019

Restrained Assembly Ratings — 1, 1-1/2, 2 and 3 Hr.

(See Items 1, 3A, 5A, 7A, 9, 9A, 9B, 10)

Unrestrained Assembly Ratings — 1, 1-1/2, 2 and 3 Hr.

(See Items 1, 3A, 5A, 7A, 9, 9A, 9B, 10)

Unrestrained Beam Ratings — 1, 1-1/2, 2 and 3 Hr.

(See Items 1, 3A, 5A, 7A, 9, 10)

This design was evaluated using a load design method other than the Limit States Design Method (e.g., Working Stress Design Method). For jurisdictions employing the Limit States Design Method, such as Canada, a load restriction factor shall be used — See Guide BXUV or BXUV7

*** Indicates such products shall bear the UL or cUL Certification Mark for jurisdictions employing the UL or cUL Certification (such as Canada), respectively.**

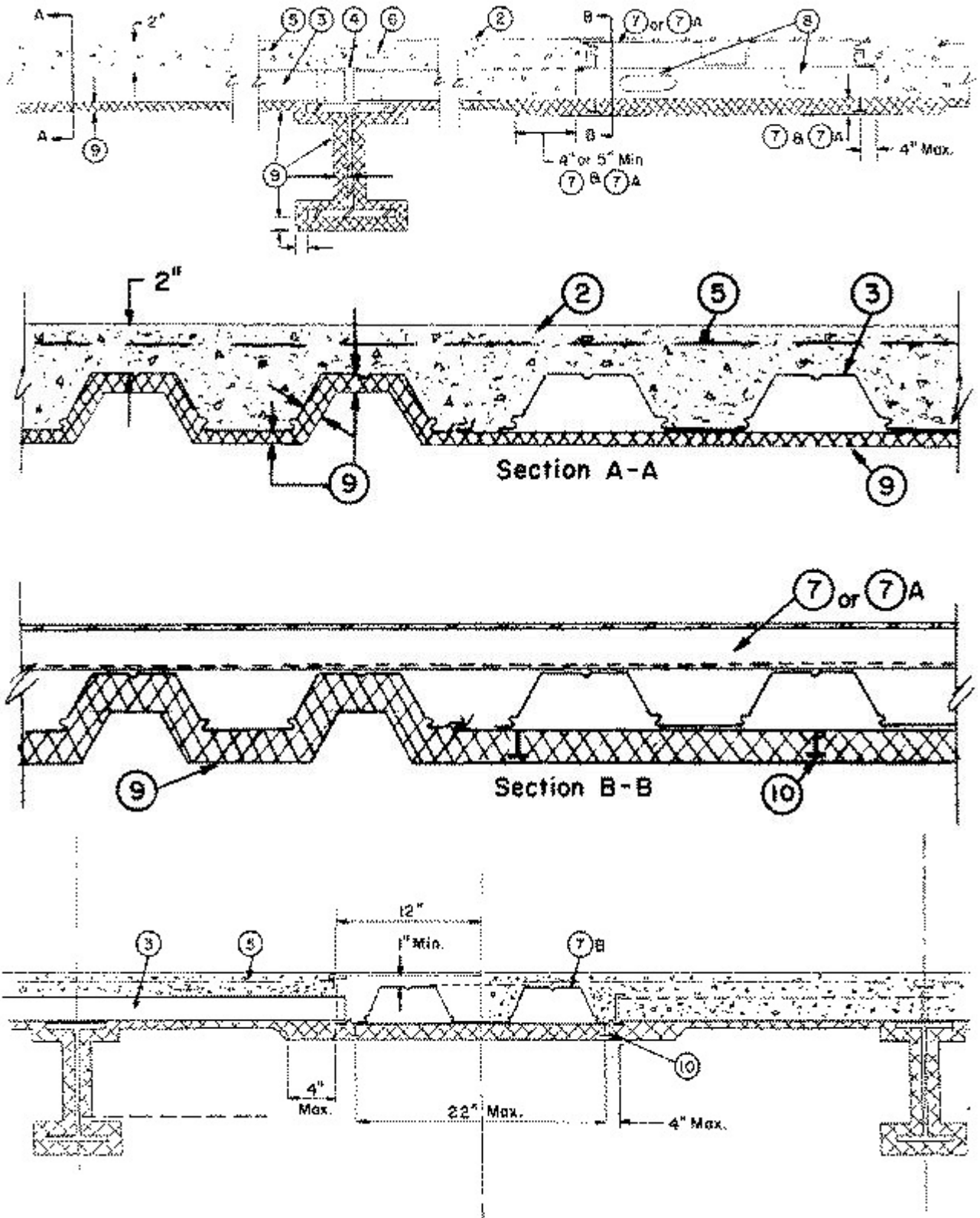

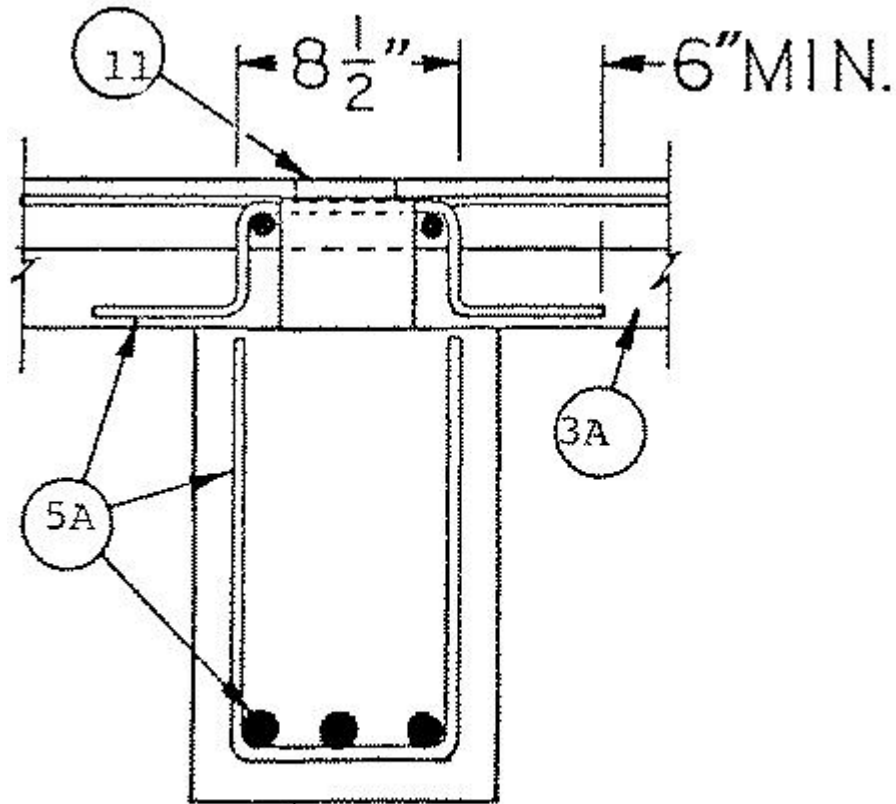
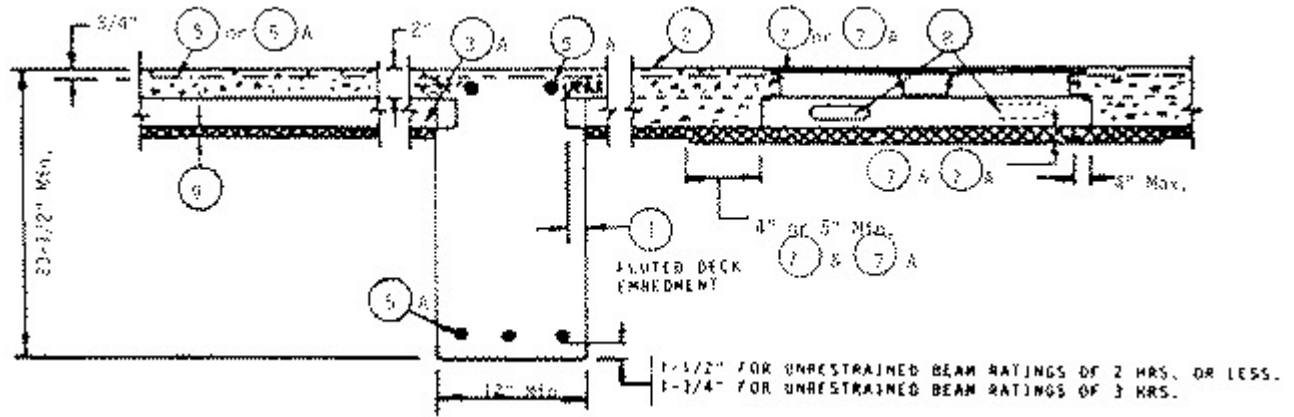
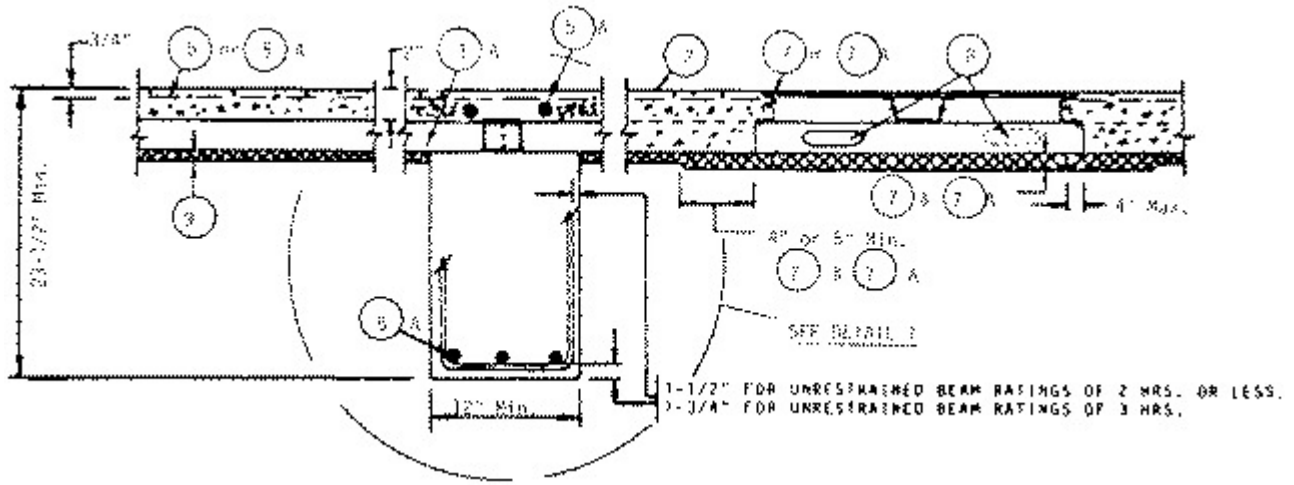

DETAIL 1

1. **Beam** — W8X20 or W8X28, min size; W8x15, min size for 1 Hr Unrestrained Beam Rating with lightweight concrete only. As an alternate to steel beams, cast in place reinforced concrete beams or girders designed in accordance with the provisions of

the Building Code Requirements for Reinforced Concrete (ACI 318-89), may be used as supports for the 3 in. deep floor units. See Item 3A.

Min width and depth of concrete beams shall be 12 and 23-1/2 in., respectively.

Fluted units shall be embedded in the concrete beams a min of 0.0139 times the clear span or 1-1/2 in., whichever is greater. The cellular units may be continuous or with a butted end joint centered over the concrete beams. For continuous floor spans, negative moment reinforcement for the slabs is required over the supporting beams.

2. Normal Weight or Lightweight Aggregate Concrete — Normal weight concrete, carbonate or siliceous aggregate; 150+ or -3 pcf unit weight, 3000 psi compressive strength, vibrated. Lightweight concrete, expanded shale or slate aggregate by rotary-kiln method, or expanded clay aggregate by rotary-kiln or sintered-grate method; 110 +or -3 pcf unit weight, 3000 psi compressive strength, 4 to 7 percent entrained air, vibrated.

3. Steel Floor And Form Units* — Composite 2 or 3 in. deep galv units. Min gauges are No. 22 MSG for fluted and No. 20/18 MSG for cellular. For spans with trench headers the allowable loading shall be based on noncomposite design. The following combination of units may be used: (1) all fluted; (2) all 24, 30 or 36 in. wide cellular; (3) any blend of fluted and 24, 30 or 36 in. wide cellular. Spacing of welds attaching units to supports shall not exceed 12 in. O.C. Adjacent units welded together 60 in. O.C. max along side joints.

ASC STEEL DECK, DIV OF ASC PROFILES L L C — 36 in. wide Types 2WH-36, 2WHS-36, 2WHF-36, 2WHF-36A, 3WxH-36, 3WxHF-36, 3WxHF-36A, 3WH-36, 3WHF-36, 3WHF-36A, 3W-36, 3WF-36. All units may be galvanized or Prime Shield. Non-cellular decks may be vented designated with "V" suffix to the product name.

CANAM STEEL CORP — 36 in. wide Type P-3623 composite; 24 in. wide Type P-2432 composite.

KAM INDUSTRIES LTD, DBA CORDECK — QL Types, 24 in. wide 2 or 3 in. 99, AKX, WKX, AKD, WKD; 36 in. wide 2 or 3 in. 99, AKX, WKX, AKD, WKD; 24 or 30 in. wide, 3 in. QL-GKX, -GKXH, -GKX-A.

CANAM STEEL CORP — 24 or 36 in. wide Types LF2, LF3. Types LF2, LF3 may be phos/ptd.

DECK WEST INC — 36 in. wide Type 2-DW or 3-DW.

DESIGN ASSISTANCE CONSTRUCTION SYSTEMS INC — 24 in. wide Type DACS2.0CD, or DACS3.0CD.

EPIC METALS CORP — 24 or 30 in. wide Types EPC2, EPC3.

MARLYN STEEL DECKS INC — Type 2.0 CF or 3.0 CF.

NEW MILLENNIUM BUILDING SYSTEMS L L C — 24 or 36 in. wide Types 2.0CD, 3.0CD, 2.0CFD, 3.0CFD, 3.0CFDES. Fluted units may be phos/painted or galvanized.

STEEL MASTERS INTERNATIONAL DEPENDABLE STEEL — 36 in. wide Types 2WH-36, 3WH-36. Units may be phos/painted or galvanized.

VERCO DECKING INC - A NUCOR CO — FORMLOK™ deck types PLW2, W2, PLW3, W3. Units are min 24 in. wide and may be galvanized or phos./ptd. Units may be cellular with the suffix "CD" added to the product name, respectively. All non-cellular deck may be vented or non-vented.

VULCRAFT, DIV OF NUCOR CORP — 24 or 36 in. wide Types 2VLI, 2.0PLVLI, 3VLI, 3.0PLVLI, 2VLP, 2.0PLVLP, 3VLP, 3.0PLVLP. Types 2VLI, 2.0PLVLI, 3VLI, 3.0PLVLI units may be phos/ptd. 24 or 36 in. wide galv or phos/ptd Types 2.0 SB, 3.0 SB.

Alternate Construction — Noncomposite units of the same type listed above may be used provided allowable loading is calculated on the basis of noncomposite design.

3A. **Steel Floor and Form Units*** — (For use with alternate cast in place concrete beams)— Composite 3 in. deep galv units. Fluted units may be uncoated. Min gauges are 20 MSG for fluted and 20/20 MSG for cellular. The ratio of blended units shall not exceed one 24 in. wide cellular unit to 36 in. wide fluted unit for the cast in place concrete frame buildings.

KAM INDUSTRIES LTD, DBA CORDECK — QL Types 24 or 36 in. wide 3 in. 99, 24 or 30 in. wide 3 in. QL-GKX, -GKX-A, -GKXH; units may be welded or fastened together with No. 10 self-drilling, self-tapping steel screws 60 in. OC. The length of the screws shall be sufficient to fully penetrate adjacent floor units.

4. **Joint Cover** — 2 in. wide pressure-sensitive cloth tape applied following the contour of the steel floor units.

5. **Welded Wire Fabric** — 6 x 6 - W1.4 x W1.4.

5A. **Reinforcement** — Deformed bars of grade 60 steel, for use in floors supported by reinforced concrete beams or girders. Min size No. 3 bars for use as negative reinforcement or vertical stirrups for beams, girders or slabs. Min No. 5 bars for use as positive reinforcement for beams or girders. Min net concrete cover on the beam or girder bottom reinforcements, shall be 1-1/2 in. for Restrained Assembly Ratings up to 3 Hr and Unrestrained Assembly and Beam Ratings up to 2 Hr. For 3 Hr Unrestrained Assembly and Beam Ratings, 1-3/4 in. cover is required. When continuous cellular units intersect the supporting concrete beams (interrupting the beam stirrups), short pieces of additional stirrups shall be placed in the top part of the beam above the units.

6. **Shear Connector Studs — Optional** — Studs, 3/4 in. diam by 3 in. long for 2 in. deep floor units to 4 in. long for 3 in. deep floor units, headed type or equivalent per AISC Specifications. Welded to the top flange of beam through the steel floor units.

7. **Trench Header** — (Bearing the UL Listing Mark.) Constructed of steel with metal edge screeds. When the trench header is located near the supports the load carrying capacity of the span may be based on the allowable moment or shear stress of the form units at the edge of the trench away from the support, or on the allowable composite moment or shear capacity of the slab at the center of the span, whichever governs. The Spray-Applied Fire Resistive Materials thickness on floor units below this trench header shall be 7/8 in. under the valleys and flat plates and 1-1/8 in. in the crests for a max 2 Hr rating. This thickness shall extend a min of 5 in. beyond the edges of the trench header.

7A. **Trench Header** — Trench header (Bearing the UL Listing Mark), without the bottom pan may be used only with 3 in. deep units and with steel studs and discs (Item 10) on underside of the units. The allowable superimposed load for spans with bottomless trench shall be based on noncomposite design. This trench header, ranging in width from min 12 in. to max 36 in., consists of two cell closers which conform to the contour of the floor units, placed along the sides of the desired trench location and welded to the floor units. The side rail, consisting of extruded aluminum screeds secured to galv steel channels (min No. 18 MSG) are positioned over the cell closers, aligned and welded or riveted to the closers and floor units. A separate U-shaped channel (min No. 18 MSG) serving as the power compartment, is welded to the floor units. Steel cover plates, 1/4 in. thick shall be secured to the side rail. In bottomless trench headers wider than 18 in., each side joint of the steel floor units shall be welded or riveted together with a 1 in. long weld near the trench header centerline. For QL-GKX-24 or -30 cellular floor units only, a separate KED-PTS (UL Listed) power transition sleeve is secured to power compartment with one rivet or screw. The use of this trench requires additional protection underneath the trench. Fireproofing thickness shall be as follows:

**Min Spray Applied Fire
Resistive Mtl Thkns In.**

Rating Hr	Crests	Valley
1	1 3/16	1
1 1/2	1 1/2	1 1/4
2	1 3/4	1 5/8
3*	2 1/2	2 5/16

These thickness shall extend a min of 4 in. beyond the edge of the trench header.

*Unrestrained Assembly Rating is 2 Hr. Restrained Assembly Rating limited to use of normal weight concrete.

7B. **Feeder Duct System** — (As an alternate to Items 7 or 7A). Consists of 3 in. deep, nom 24 in. wide, 20/18 MSG Type QL-WKM or QL-WKM-E cellular steel floor unit (feeder duct) and nom 24 by 24 in. junction boxes. The valley between the two cells of the feeder duct may or may not be covered by a steel plate to form a third cell. Feeder duct installed at the same elevation and perpendicular to 2 or 3 in. deep fluted and/or cellular steel floor units which are cantilevered from support beams on one or both sides of the feeder duct. The junction boxes consisting of extruded aluminum screeds, 18 galv steel outside flute closures, 16 galv steel compartment divider and 0.21 in. thick steel cover plate are used at intersections of 2 or 3 in. cellular units and the feeder duct, where desired. Bottom tabs of the flute closures are fastened to the valleys of the 2 or 3 in. units and to the feeder duct with self-drilling tek fasteners, while the cover plate is retained in position by four latch clips, one near each corner of the plate. The height and level of the aluminum screed are adjusted by four adjustment screws, two each on opposite sides. In between the junction boxes the ends of the 2 or 3 in. fluted and/or cellular units are covered with steel end closure angles tack-welded to the top of the units.

Welded wire fabric (Item 5) extends over the feeder duct between junction boxes. The allowable superimposed load for spans with the feeder duct system shall be based on noncomposite design. Steel studs with discs (Item 10) shall be welded to the underside of the feeder duct in two rows. The spacing between rows shall not exceed 22 in. OC and the spacing of studs in each row shall not exceed 24 in. OC. The use of this feeder duct system requires additional protection underneath the feeder duct.

Rating Hr	Min Spray Applied Fire Resistive Mtl Thkns In.
1	1 1/4
1 1/2	1 1/2
2	1 3/4
3*	2 1/2

These thicknesses shall extend a min of 4 in. beyond the edges of the feeder duct.

*Unrestrained Assembly Rating is 2 Hr Restrained Assembly Rating limited to use of normal weight concrete.

KAM INDUSTRIES LTD, DBA CORDECK — 24 in. wide Type QL-WKM or QL-WKM-E.

8. **Access Openings** — As required with grommets.

9. **Spray-Applied Fire Resistive Materials** — *Applied by mixing with water and spraying in more than one coat to a final thickness as shown above and below to steel surfaces which must be clean and free of dirt, loose scale and oil. When steel deck is used, the area between the steel deck and the beams top flange shall be filled. Min avg and min ind density of 15/14 pcf respectively. Min avg and min ind density of 22/19 pcf respectively for Types Z-106, Z106/HY and Z-106/G. Min avg and min ind density of 40/36 pcf respectively for Z-146. Min avg and min ind density of 19/18 pcf respectively for Type 7GP and 7HD. Application to steel deck requires the installation of expanded metal lath with Type Z-146. See Item 12. For method of density determination see Design Information Section. Types 4, 5GP, 5AR, 5GP/AR, 5EF/AR, 5MD/AR, 7GP, 7HD, 8GP, 9GP may be used only in general floor areas without concrete penetrations with all fluted steel floor units or blends consisting of one or more fluted units to one 24 in. wide max cellular unit, 1-1/2 or 3 in. deep, with cells spaced approx 6 and 8 in. respectively. Type Z-106 may be used only in general floor areas without concrete penetrations with all fluted steel floor units. Use of a spatter coat, Types DK, DK2, DK3, SK-1 or SK-III is required on all cellular units with flat plate on the bottom, optional on other steel surfaces. Thickness of the spatter coat is included in the total final thickness of the protection material.

Restrained Assembly Rating Hr	Min Required Unrestrained Beam Rating Hr	Min Spray Applied Fire Resistive Mtl Thkns on Beam In.				
		NW W8x20	W8x28	W8x15	LW W8x20	W8x28
1	1	1/2	1/2	5/8	5/8	5/8
1-1/2	1	1/2	1/2	5/8	5/8	5/8
1-1/2	1 1/2	3/4	3/4	—	7/8	3/4

2	1	1/2	1/2	5/8	5/8	5/8
2	2	1	7/8	—	1-1/8	1
3	3	1-7/16	1-1/4	—	1-3/4	1-9/16

Concrete Type	Min Spray Applied Fire Resistive Mtl Thkns In. General Floor Area	Restrained Assembly Rating Hr	Unrestrained Assembly Rating Hr
NW	1/2	1	1
LW	9/16	1	1
LW	3/4	1 1/2	1-1/2
NW	11/16	2	1-1/2
NW	5/8*	2	1
LW	5/8**	2	1
NW	13/16	2	2
LW	15/16	2	2
NW	1-1/4	3	3
LW	1-7/16	3	3

*Only applicable to floors consisting of all 2 or 3 in. fluted units without trench headers or other (insert) penetrations.

**Only applicable to floors consisting of 2 or 3 in. fluted and/or cellular units without trench header or other (insert) penetrations.

ARABIAN VERMICULITE INDUSTRIES — Type MK-6/HY, MK-6/HB, MK-10 HB, MK-10 HB Extended Set, MK-6s, SK-3, Z-106, Z-106/G, Z-146 investigated for exterior use, Sonophone 1, Sonophone 5, Sonophone 35.

GCP KOREA INC — Types MK-6/CBF, MK-6/ED, MK-6 GF, MK-6/HY, MK-6/HB, MK-10 HB, MK-10 HB Extended Set, MK-6s, Monokote Acoustic 1, Monokote Acoustic 5, SK-3, Z-106, Z-106/G, Z-106/HY, Z-146 investigated for exterior use, Monokote Acoustic 35.

PYROK INC — Type LD.

SOUTHWEST FIREPROOFING PRODUCTS CO — Types 4, 5, 5EF, 5GP, 5AR, 5GP/AR, 5EF/AR, 5MD/AR, 5MD, 7GP, 7HD, 8EF, 8GP, 8MD, 9EF, 9GP, 9MD, DK, DK2, DK3.

GCP APPLIED TECHNOLOGIES INC — Types MK-6 GF, MK-6/HY, MK-10 HB, MK-10 HB Extended Set, MK-6/HB, MK-6s, Monokote Acoustic 1, Monokote Acoustic 5, RG, SK-3, Z-106, Z-106/G, Z-106/HY, Z-146 investigated for exterior use, Monokote Acoustic 35.

10. Steel Studs With Discs — The stud consists of a No. 12 SWG wire with one end welded to a 1-3/16 in. diam No. 28 MSG (0.020 in. thick) galv steel disc. The length of studs shall be 3/8 in. less than the thickness of the Spray-Applied Fire Resistive Materials. The total number of studs shall avg at least one stud per 236 sq. in. of cellular floor units beneath the trench header. The ends of studs opposite the discs shall be welded to the cellular floor units in rows running parallel with the trench header. The distance between the outer rows and the edge of the trench header shall not exceed 4 in. The spacing between the rows shall not exceed 22 in. The spacing between studs in each row shall not exceed 24 in.

11. **Electrical Inserts** — (Not shown) — Classified as "**Outlet Boxes and Fittings Classified for Fire Resistance**" * may be used with normal weight concrete only.

(1) KAM INDUSTRIES LTD, DBA CORDECK Inserts

(Tapmate II, -II-EA, -II-FN, -II-EAFN; Series KEB)

Installed per accompanying installation instructions over factory-punched holes in QL-AKX or QL-WKX floor units. Inserts are used in the pre-active, active or abandoned condition. Spacing shall be not more than one insert in each 7 1/2 sq ft of floor area with not less than 25 1/2 in. between edges of adjacent inserts. For ratings of 2 Hr max, the required Spray-Applied Fire Resistive Materials thickness on QL-AKX or QL-WKX floor units is 1 3/16 in. For 3 Hr max ratings, the required thickness below inserts shall be 1-13/16. When Tapmate II or II-EA electrical inserts are used. When Tapmate II-FN or II-EAFN electrical inserts are used, no additional thickness of Spray-Applied Fire Resistive Materials is required beyond that specified for the general floor area. For the Tapmate II or II-EA inserts, the required thickness below inserts shall be sprayed the entire width and length of floor units between supports and extend beyond the edge of inserts onto adjacent units for a horizontal width of 12 in. The holes cut in insert cover for passage of wires shall be no more than 1/8 in. larger diam than the wire. For abandonment of Tapmate inserts, see installation instructions. Abandonment requires use of KEB-PC or -PCL insert cover with no holes in it (for all Tapmate inserts), or an abandonment plate for Tapmate II only, or a KEB-PC2 or -PC2-A1 abandonment cover for Tapmate II-EA and II-EAFN only.

The Tapmate II-FN insert may use KEB-HP-1 outlet box fittings in lieu of the KEB-PC flush cover fittings.

KAM INDUSTRIES LTD, DBA CORDECK — Tapmate II, II-EA, II-FN, II-EAFN; Series KEB.

(Tapmate IIIFN, IIIEAFN, V; Series KEC).

Installed per accompanying installation instructions over factory-punched holes in QL-AKD or QL-WKD floor units. Inserts are used in the pre-active, active or abandoned condition. Spacing shall be not more than one insert in each 7 1/2 sq ft of floor area with not less than 25 1/2 in. between edges of adjacent inserts. When Tapmate III FN or III EAFN electrical inserts are used, no additional thickness of Spray-Applied Fire Resistive Materials is required beyond that specified for the general floor area. The holes cut in insert cover for passage of wires shall be no more than 1/8 in. larger diam than the wire. For abandonment of Tapmate inserts, see installation instructions.

The Tapmate III insert may use KEB-HP-1; Series KEC outlet box fittings with the same hourly rating, insert spacing and fireproofing thicknesses as specified for the Tapmate III-EAFN electrical inserts.

Abandonment of Tapmate III-FN requires use of KEC-PC insert cover with no holes in it. Abandonment of Tapmate III-EAFN requires use of KEC-PC5 insert cover with no holes in it and use of KEC-PC6 insert cover in lieu of either KEC-PC12 or -PC13 insert cover.

KAM INDUSTRIES LTD, DBA CORDECK — Tapmate II, -II-EA, -II-FN, -II-EAFN; Series KEB, Tapmate IIIFN, IIIEAFN; Series KEC, Tapmate V.

12. **Metal Lath** — (Not Shown) —(Required with Z-146, Sonophone 35 and Monokote Acoustic 35, otherwise optional)—Metal lath shall be 3/8 in. expanded diamond mesh, weighing 2.5 lb per sq yd. Secured to underside of steel deck with No. 12 by 3/8 in. pan head self-drilling, self-tapping screws and steel washers with an outside diam of 1/2 in. screws spaced 12 in. OC in both directions with lath edges overlapped approx 3 in.

13. **Metal Lath** — (Not Shown) — Where Type 7HD is applied to steel deck, 3/8 in. metal ribbed lath weighing 3.4 lb/yd² shall be secured to the underside of the steel deck (ribs upward) with S-12 by 3/8 in. long pan head, self-tapping steel screws spaced 12 in. OC in all directions. Steel screws shall be fitted with 1/2 in. diameter steel washers. Adjacent pieces of lath shall be overlapped 1 in. min.

*** Indicates such products shall bear the UL or cUL Certification Mark for jurisdictions employing the UL or cUL Certification (such as Canada), respectively.**

Last Updated on 2019-10-04

The appearance of a company's name or product in this database does not in itself assure that products so identified have been manufactured under UL's Follow-Up Service. Only those products bearing the UL Mark should be considered to be Certified and covered under UL's Follow-Up Service. Always look for the Mark on the product.

UL permits the reproduction of the material contained in the Online Certification Directory subject to the following conditions: 1. The Guide Information, Assemblies, Constructions, Designs, Systems, and/or Certifications (files) must be presented in their entirety and in a non-misleading manner, without any manipulation of the data (or drawings). 2. The statement "Reprinted from the Online Certifications Directory with permission from UL" must appear adjacent to the extracted material. In addition, the reprinted material must include a copyright notice in the following format: "© 2020 UL LLC"