

BXUV.N708

Design/System/Construction/Assembly Usage Disclaimer

- Authorities Having Jurisdiction should be consulted in all cases as to the particular requirements covering the installation and use of UL Certified products, equipment, system, devices, and materials.
- Authorities Having Jurisdiction should be consulted before construction.
- Fire resistance assemblies and products are developed by the design submitter and have been investigated by UL for compliance with applicable requirements. The published information cannot always address every construction nuance encountered in the field.
- When field issues arise, it is recommended the first contact for assistance be the technical service staff provided by the product manufacturer noted for the design. Users of fire resistance assemblies are advised to consult the general Guide Information for each product category and each group of assemblies. The Guide Information includes specifics concerning alternate materials and alternate methods of construction.
- Only products which bear UL's Mark are considered Certified.

BXUV - Fire Resistance Ratings - ANSI/UL 263 Certified for United States

BXUV7 - Fire Resistance Ratings - CAN/ULC-S101 Certified for Canada

See General Information for Fire-resistance Ratings - ANSI/UL 263 Certified for United States Design Criteria and Allowable Variances

See General Information for Fire Resistance Ratings - CAN/ULC-S101 Certified for Canada Design Criteria and Allowable Variances

Design No. N708

August 13, 2015

Restrained Beam Ratings — 1, 2, 3 and 4 Hr.

Unrestrained Beam Ratings — 1, 1-1/2, 2, 3 and 4 Hr.

This design was evaluated using a load design method other than the Limit States Design Method (e.g., Working Stress Design Method). For jurisdictions employing the Limit States Design Method, such as Canada, a load restriction factor shall be used — See Guide BXUV or BXUV7

*** Indicates such products shall bear the UL or cUL Certification Mark for jurisdictions employing the UL or cUL Certification (such as Canada), respectively.**

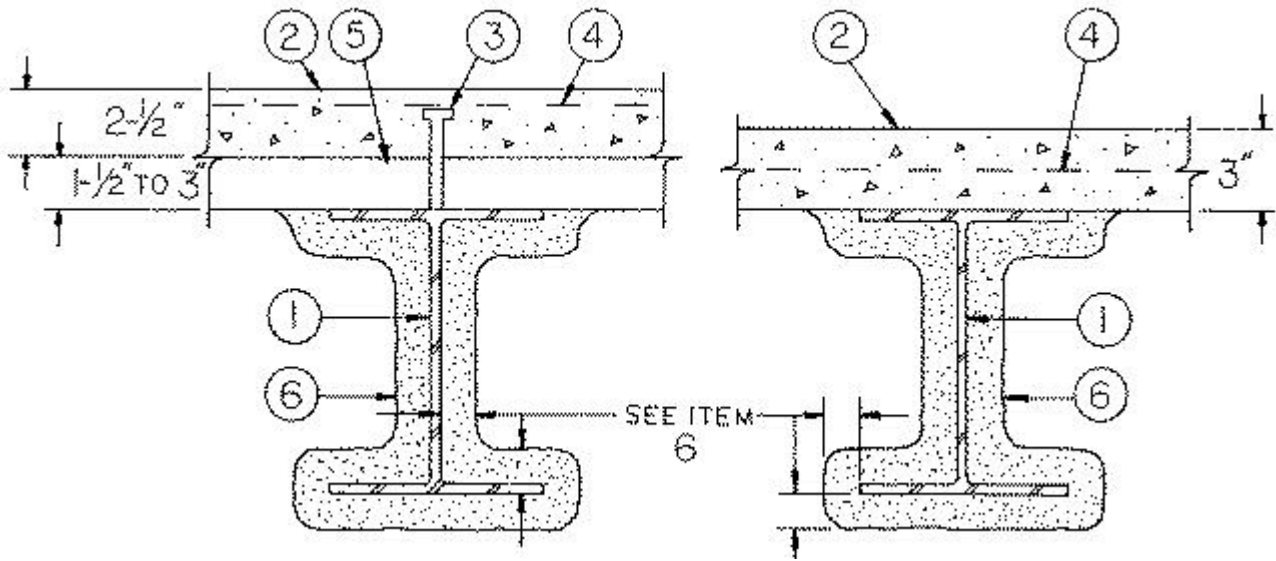

1. **Steel Beam** — W8x28 min size.

2. **Normal Weight or Lightweight Concrete** — Compressive strength, 3000 psi. For normal weight concrete either carbonate or siliceous aggregate may be used. Unit weight, 148 pcf. For lightweight concrete, unit weight 110 pcf.

3. **Shear Connector** — (Optional) — Studs, 3/4 in. diam headed type or equivalent per AISC specifications. Welded to the top flange of beam through the steel floor units.

4. **Welded Wire Fabric** — (Optional) — 6x6-10/10 SWG.

5. **Steel Floor and Form Units*** — 1-5/16 in. deep corrugated units; or 1-1/2 to 3 in. deep fluted or cellular units, welded to beam.

6. **Spray-Applied Fire Resistive Materials*** — Applied by mixing with water and spraying in more than one coat to the beam to the final thicknesses shown below. When fluted or corrugated steel floor units are used, crest areas shall be filled with Spray-Applied Fire Resistive Materials above the beam. Beam surfaces must be clean and free of dirt, loose scale and oil. Min avg and min ind density of 15/14 pcf respectively. Min avg and min ind density of 19/18 pcf respectively for Types 7GP and 7HD. For method of density determination, see Design Information Section.

Min Thkns In.

Rating Hr	Restrained Beam Rating Hr	Unrestrained Beam Rating Hr
1	1/2	1/2
1-1/2	11/16	13/16
2	15/16	1-1/16
3	1-7/16	1-9/16
4	1-15/16	2

The thicknesses of Spray-Applied Fire Resistive Materials shown in the table below are applicable when the beams are supporting solid lightweight concrete slabs or lightweight concrete floor assemblies containing only fluted floor or form units.

Min Thkns In.

Rating Hr	Restrained Beam Rating Hr	Unrestrained Beam Rating Hr
1	7/16	7/16

1-1/2	1/2	3/4
2	13/16	1
3	1-5/16	1-5/16
4	1-5/8	1-5/8

The thicknesses of Spray-Applied Fire Resistive Materials shown in the table below are applicable when the thickness applied to the beams' lower flange edges is reduced to one-half that shown in the table:

Rating Hr	Min Thkns In.	
	Restrained Beam Rating Hr	Unrestrained Beam Rating Hr
1	9/16	9/16
1-1/2	3/4	7/8
2	1-1/16	1-3/16
3	1-5/8	1-3/4
4	2-3/16	2-5/16

The thicknesses of Spray-Applied Fire Resistive Materials shown in the table below are applicable when the thickness applied to the beams' lower flange edges is reduced by one-half and the beams are supporting solid lightweight concrete slabs or lightweight concrete floor assemblies containing only fluted floor or form units

Rating Hr	Min Thkns In.	
	Restrained Beam Rating Hr	Unrestrained Beam Rating Hr
1	7/16+	7/16+
1-1/2	1/2	3/4
2	13/16	1
3	1-5/16	1-9/16
4	1-13/16	2-1/16

+Thickness applied to beams' lower flange edges shall be a min of 1/4 in.

ARABIAN VERMICULITE INDUSTRIES — MK-6/CBF, MK-6/ED, MK-6/HY, MK-6/HY Extended Set, MK-6/HB, MK-10 HB, MK-10 HB Extended Set, MK-6s, Sonophone 1.

GCP KOREA INC — Types MK-6/CBF, MK-6/ED, MK-6/HY, MK-6/HY Extended Set, MK-10 HB, MK-10 HB Extended Set, MK-6/HB, MK-6s, Monokote Acoustic 1.

PYROK INC — Type LD.

SOUTHWEST FIREPROOFING PRODUCTS CO — Types 4, 5, 5EF, 5GP, 5MD, 7GP, 7HD, 8EF, 8GP, 8MD, 9EF, 9GP, 9MD.

GCP APPLIED TECHNOLOGIES INC — Types MK-6/HY, MK-6/HY Extended Set, MK-10 HB, MK-10 HB Extended Set, MK-6/HB, MK-6s, RG, Monokote Acoustic 1.

*** Indicates such products shall bear the UL or cUL Certification Mark for jurisdictions employing the UL or cUL Certification (such as Canada), respectively.**

Last Updated on 2015-08-13

The appearance of a company's name or product in this database does not in itself assure that products so identified have been manufactured under UL's Follow-Up Service. Only those products bearing the UL Mark should be considered to be Certified and covered under UL's Follow-Up Service. Always look for the Mark on the product.

UL permits the reproduction of the material contained in the Online Certification Directory subject to the following conditions: 1. The Guide Information, Assemblies, Constructions, Designs, Systems, and/or Certifications (files) must be presented in their entirety and in a non-misleading manner, without any manipulation of the data (or drawings). 2. The statement "Reprinted from the Online Certifications Directory with permission from UL" must appear adjacent to the extracted material. In addition, the reprinted material must include a copyright notice in the following format: "© 2020 UL LLC"