

Design/System/Construction/Assembly Usage Disclaimer

- Authorities Having Jurisdiction should be consulted in all cases as to the particular requirements covering the installation and use of UL Certified products, equipment, system, devices, and materials.
- Authorities Having Jurisdiction should be consulted before construction.
- Fire resistance assemblies and products are developed by the design submitter and have been investigated by UL for compliance with applicable requirements. The published information cannot always address every construction nuance encountered in the field.
- When field issues arise, it is recommended the first contact for assistance be the technical service staff provided by the product manufacturer noted for the design. Users of fire resistance assemblies are advised to consult the general Guide Information for each product category and each group of assemblies. The Guide Information includes specifics concerning alternate materials and alternate methods of construction.
- Only products which bear UL's Mark are considered Certified.

BXUV - Fire Resistance Ratings - ANSI/UL 263 Certified for United States

BXUV7 - Fire Resistance Ratings - CAN/ULC-S101 Certified for Canada

[See General Information for Fire-resistance Ratings - ANSI/UL 263 Certified for United States](#)

[Design Criteria and Allowable Variances](#)

[See General Information for Fire Resistance Ratings - CAN/ULC-S101 Certified for Canada](#)

[Design Criteria and Allowable Variances](#)

Design No. J701

October 17, 2017

Restrained Assembly Rating — 2 Hr.

Unrestrained Assembly Rating — 1 Hr.

This design was evaluated using a load design method other than the Limit States Design Method (e.g., Working Stress Design Method). For jurisdictions employing the Limit States Design Method, such as Canada, a load restriction factor shall be used — See Guide [BXUV](#) or [BXUV7](#)

*** Indicates such products shall bear the UL or cUL Certification Mark for jurisdictions employing the UL or cUL Certification (such as Canada), respectively.**



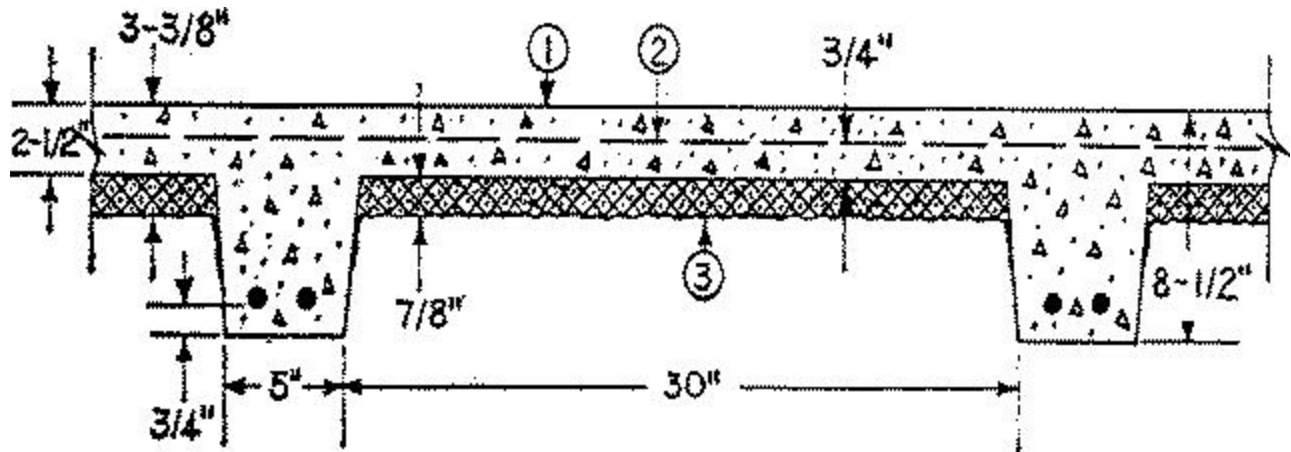

1. **Normal-Weight Concrete** — Siliceous or carbonate aggregate, 3000 psi compressive strength, to be designed with continuity over the supports.

1A. **Vermiculite Aggregate Concrete*** — (Not Shown) — Optional. Applied over concrete slab, Item 1. The vermiculite concrete is to 2 in. min with a max thickness of 6 in.

SIPLAST INC

1B. **Cellular Concrete — Roof Topping Mixture*** — (Not Shown) — Optional — Foam Concentrate mixed with water, Portland Cement and UL Classified Vermiculite Aggregate per manufacturer's application instructions. Cast dry density of 33 (+ or -) 3.0 pcf and 28-day compressive strength of min 250 psi as determined in accordance with ASTM C495-86. The cellular concrete topping thickness shall be 2 in. min with a max thickness of 6 in.

SIPLAST INC — Mix No. 3.

2. **Welded Wire Fabric** — 6x6 — 6/6SWG.

3. **Spray-Applied Fire Resistive Materials*** — Spray applied by mixing with water in more than one coat to a final thickness of 7/8 in., to concrete surfaces which must be clean and free of dirt or oil. Min avg and min ind density of 15/14 pcf respectively. Min avg and min ind density of 19/18 pcf respectively for Type 7GP and 7HD. For method of density determination, refer to Design Information Section.

ARABIAN VERMICULITE INDUSTRIES — MK-6/CBF, MK-6/ED, MK-6/HY, MK-6s, MK-6 GF, MK-6 GF Extended Set, MK-10 HB, MK-1000/HB, MK-1000/HB Extended Set, Sonophone 1.

GCP KOREA INC — Types MK-6/CBF, MK-6/ED, MK-6/HY, MK-6s, MK-6 GF, MK-6 GF Extended Set, MK-10 HB, MK-1000/HB, MK-1000/HB Extended Set, Monokote Acoustic 1.

PYROK INC — Type LD.

Carboline Global Inc. — Types 4, 5, 5EF, 5GP, 5MD, 7GP, 7HD, 8EF, 8GP, 8MD, 9EF, 9GP, 9MD.

GCP APPLIED TECHNOLOGIES INC — Types MK-6/HY, MK-6s, MK-6 GF, MK-6 GF Extended Set, MK-10 HB, MK-1000/HB, MK-1000/HB Extended Set, Monokote Acoustic 1, RG.

3A. **Spray-Applied Fire Resistive Materials*** — (Not Shown) — In lieu of Item 3 the following Spray-Applied Fire Resistive Materials may be applied by mixing with water and spraying in multiple coats to a final thickness of 7/8 in. to concrete surfaces which must be clean and free of dirt or oil. Min avg and min ind density 22/19 pcf respectively. Min avg and min ind density of 40/36 pcf respectively for Z-146, Sonophone 35, and Monokote Acoustic 35. For method of density determination, refer to

Design Information Section, Sprayed Material.

ARABIAN VERMICULITE INDUSTRIES — Types Sonophone 5, Z-106, Z-106/G, Z-106/HY, Z-146 investigated for exterior use, Sonophone 35.

GCP KOREA INC — Types Monokote Acoustic 5, Z-106, Z-106/G, Z-106/HY, Z-146 investigated for exterior use, Monokote Acoustic 35.

GCP APPLIED TECHNOLOGIES INC — Types Monokote Acoustic 5, Z-106, Z-106/G, Z-106/HY, Z-146 investigated for exterior use, Monokote Acoustic 35.

4. **Metal Lath** — (Not Shown)—(Required with Z-146, Sonophone 35, and Monokote Acoustic 35, otherwise optional)—Metal lath shall be 3/8 in. expanded diamond mesh, weighing 2.5 lb per sq yd. Secured to underside of slab through steel washers with an outside diam of 1/2 in. with fasteners spaced 12 in. OC in both directions with lath edges overlapped approx 3 in.

5. **Metal Lath** — (Not Shown) — Required when Type 7HD is applied to - Metal lath shall be 3/8 in. expanded diamond mesh, weighing 3.4 lb per sq yd. Secured to underside through steel washers with an outside diam of 1/2 in. with fasteners spaced 12 in. OC in both directions with lath edges overlapped approx 3 in.

*** Indicates such products shall bear the UL or cUL Certification Mark for jurisdictions employing the UL or cUL Certification (such as Canada), respectively.**

Last Updated on 2017-10-17

The appearance of a company's name or product in this database does not in itself assure that products so identified have been manufactured under UL Solutions' Follow - Up Service. Only those products bearing the UL Mark should be considered to be Certified and covered under UL Solutions' Follow - Up Service. Always look for the Mark on the product.

UL Solutions permits the reproduction of the material contained in Product iQ subject to the following conditions: 1. The Guide Information, Assemblies, Constructions, Designs, Systems, and/or Certifications (files) must be presented in their entirety and in a non-misleading manner, without any manipulation of the data (or drawings). 2. The statement "Reprinted from Product iQ with permission from UL Solutions" must appear adjacent to the extracted material. In addition, the reprinted material must include a copyright notice in the following format: "©2024 UL LLC."

