

Design/System/Construction/Assembly Usage Disclaimer

- Authorities Having Jurisdiction should be consulted in all cases as to the particular requirements covering the installation and use of UL Certified products, equipment, system, devices, and materials.
- Authorities Having Jurisdiction should be consulted before construction.
- Fire resistance assemblies and products are developed by the design submitter and have been investigated by UL for compliance with applicable requirements. The published information cannot always address every construction nuance encountered in the field.
- When field issues arise, it is recommended the first contact for assistance be the technical service staff provided by the product manufacturer noted for the design. Users of fire resistance assemblies are advised to consult the general Guide Information for each product category and each group of assemblies. The Guide Information includes specifics concerning alternate materials and alternate methods of construction.
- Only products which bear UL's Mark are considered Certified.

BXUV - Fire Resistance Ratings - ANSI/UL 263 Certified for United States

BXUV7 - Fire Resistance Ratings - CAN/ULC-S101 Certified for Canada

[See General Information for Fire-resistance Ratings - ANSI/UL 263 Certified for United States Design Criteria and Allowable Variances](#)

[See General Information for Fire Resistance Ratings - CAN/ULC-S101 Certified for Canada Design Criteria and Allowable Variances](#)

Design No. D925

August 02, 2024

Restrained Assembly Ratings — 3/4, 1, 1-1/2, 2 or 3 Hr (See Items 1, 3A, 6, 10)

Unrestrained Assembly Rating — 0 Hr (See Items 3, 3A, 4, 4A, 10)

Unrestrained Beam Ratings — 1, 1-1/2, 2, 3 and 4 Hr (See Items 4, 4A, 10)

Restricted Load Condition — See Supports and Item 4C



This design was evaluated using a load design method other than the Limit States Design Method (e.g., Working Stress Design Method). For jurisdictions employing the Limit States Design Method, such as Canada, a load restriction factor shall be used — See Guide [BXUV](#) or [BXUV7](#)

*** Indicates such products shall bear the UL or cUL Certification Mark for jurisdictions employing the UL or cUL Certification (such as Canada), respectively.**

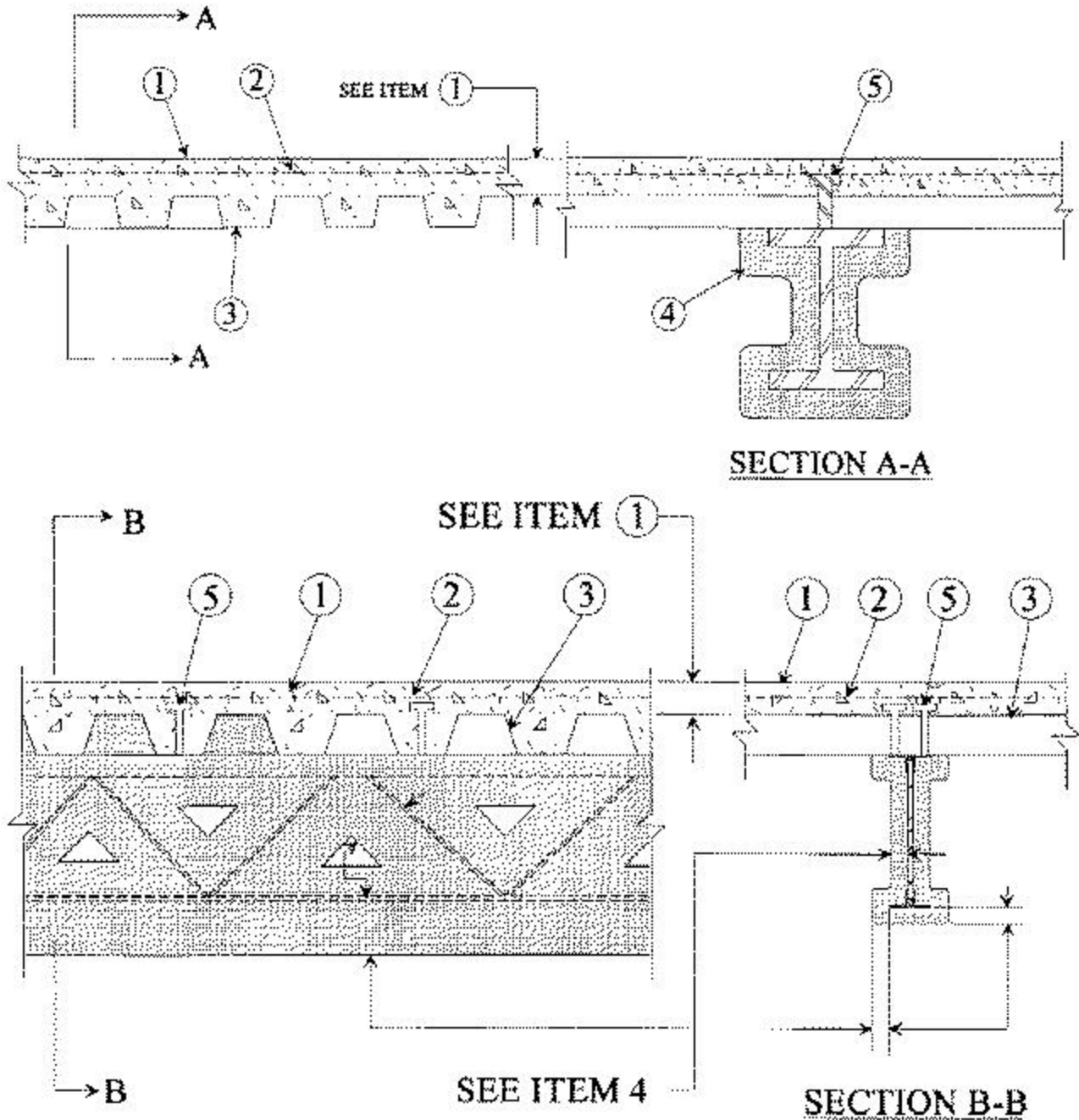

Supports — W8x28 or alternate (per Section IV.6 in the front of the Fire Resistance Directory) steel beam when beam substitution applied.

1. Normal Weight or Lightweight Concrete — Normal weight concrete carbonate or siliceous aggregate, 3500 psi compressive strength, vibrated. Lightweight concrete, expanded shale, or slate aggregate by rotary-kiln method, or expanded clay aggregate by rotary-kiln or sintered-grate method, or pumice aggregate, 3000 psi compressive strength, vibrated, 4 to 7 percent entrained air.

Restrained or Unrestrained Assembly Rating Hr (see Item 3 Note below)	Concrete (Type)	Concrete Unit Weight pcf	Concrete Thkns In.
1	Normal Weight	147-153	3-1/2
1-1/2	Normal Weight	147-153	4
2	Normal Weight	147-153	4-1/2
3	Normal Weight	147-153	5-1/4
3/4 or 1	Lightweight	107-113	2-1/2

1	Lightweight	107-120	2-5/8
1-1/2	Lightweight	107-113	3
2	Lightweight	107-113	3-1/4
2	Lightweight	107-116	3-1/4*
2	Lightweight	114-120	3-1/2
3	Lightweight	107-113	4-3/16
3	Lightweight	114-120	4-7/16

*For use with 2 or 3 in. steel floor and form units only.

2. **Welded Wire Fabric** — 6 x 6, 10 x 10 SWG.

2A. **Negative Reinforcement** — (Not Shown) - Optional - For 3/4, 1, 1-1/2 and 2 Hr Restrained Assembly Rating Only. Used in lieu of Item 2 and with Items 2B or 2C. For floor spans with concrete cast continuous over the supporting beams. Deformed bars designed to resist the support moments of the concrete slab in accordance with the latest ACI Building Code Specifications.

2B. **Fiber Reinforcement*** — (Not Shown) - For 3/4, 1, 1-1/2 and 2 Hr Restrained Assembly Rating Only. Required with Item 2A. Engineered synthetic fibers added to concrete mix to control shrinkage cracks in concrete. Fibers added to concrete mix at rate of 5 lbs of fiber for each cubic yard of concrete.

GCP APPLIED TECHNOLOGIES INC — Type Strux 90/40.

2C. **Fiber Reinforcement*** — (Not Shown) - For 3/4, 1, 1-1/2 and 2 Hr Restrained Assembly Rating Only. Required with Item 2A. Engineered synthetic fibers added to concrete mix to control shrinkage cracks in concrete. Fibers added to concrete mix at rate of 1 lbs of fiber for each cubic yard of concrete (Fibermesh 150) or 1.5 lbs of fiber for each cubic yard of concrete (Fibermesh 300).

PROPEX OPERATING CO L L C — Types Fibermesh 150 and Fibermesh 300.

3. **Steel Floor and Form Units*** — Composite or Non-Composite, 1-1/2, 1-5/8, 2 or 3 in. deep galv units or 4-1/2 in. deep non-composite galv units. Fluted units may be uncoated or phosphatized/painted. Min gauges are 22 MSG for fluted and 20/20 MSG for cellular units. The following combinations of units may be used:

(1) All 18, 24, 26 28 or 36 in. wide cellular.

(2) All fluted.

(3) One or two 3 in. deep, 12 in. wide, 18/18 MSG min cellular units, alternating with 3 in. deep fluted or other cellular.

(4) Any blend of fluted and 18, 24, 26, 28, or 36 in. wide cellular.

(5) 3 in. deep, 30 in. wide cellular with 8-1/8 in. wide valley alongside joints may be used when 3/8 in. diam reinforcing bars are placed 1-1/2 in. to each side of side joints and 1 in. above bottom of units.

(6) Corrugated, 1-5/16 in. deep, 30 in. wide, 24 MSG min galv units with shear wires factory welded to deck corrugations. Welded to supports 12 in. OC. through welding washers. For shear wire spacing of 8 in. or less the steel deck stress shall not exceed 20 KSI. For shear wire spacing greater than 8 in. OC. but less than or equal to 12 in. OC. steel deck stress shall not exceed 12 KSI.

ASC STEEL DECK, DIV OF ASC PROFILES L L C — 32 in. wide Types NH-32, NHN-32, NHF-32; 36 in. wide Types BH-36, BHN-36, BHN-35-1/4, BHF-36, BHF-36A, 2WH-36, 2WHS-36, 2WHF-36, 2WHF-36A, 3WxH-36, 3WxHF-36, 3WxHF-36A, 3WH-36, 3WHF-36, 3W-36, 3WF-36, DG3W-36, DG3WF-36. All units may be galvanized or Prime Shield. Non-cellular decks may be vented designated with a "V" suffix to the product name. Cellular deck top and bottom sections may be riveted together (designated with "Fr") vs. arc spot welded, "F".

CANAM GROUP INC — 36 in. wide Type P-3623, P-3606, P-3615 and 24 in wide Type P-2432 composite; 24 or 36 in. wide Type 3 in. LOK-Floor; 36 in. wide Types 1.5B, 1.5BI, 1.5BL and 1.5BL; 24 in. or 36 in. wide, Type LF2.

CANAM STEEL CORP — 24 in. wide, Types 1-1/2, 2 or 3 in. LOK-Floor and LOK-Floor Cell; 36 in. wide, Types 2 or 3 in. LOK-Floor and LOK-Floor Cells; 24 in. wide, Types N-LOK and N-LOK Cell; 24, 30 or 36 in. wide, Type 1-1/2 in. B-LOK and B-LOK Cell.

NEW MILLENNIUM BUILDING SYSTEMS L L C — 24 in. wide Type Versa-Dek.

DECK WEST INC — 36 in. wide Type B-DW, 2-DW or 3-DW. Side joints of 2-DW and 3-DW may be fastened together with min 1 in. long No. 12 x 14 self-drilling, self-tapping steel screw 36 in. OC.

DESIGN ASSISTANCE CONSTRUCTION SYSTEMS INC — 36 in. wide Type DACS1.5CD, or 24 in. wide Type DACS2.0CD, or DACS3.0CD.

EPIC METALS CORP — 24 in. wide Types EC150, ECP150, EC300, ECP300, EC366, ECP366, EC150, EC300 inverted, Epicore A; 30 in. wide Types ECB150, ECBR150; 36 in. wide Types EC266.

H H ROBERTSON — QL Types, 24 in. wide 3 or 3 inverted, UKX, UKX-3, 2 in. 99, AKX, 21 or 21 inverted, 121, NKX, TKX; 24 or 30 in. wide GKX, GKX-A; 36 in. wide 99, AKX, WKX; 24 26, 94, 36 in. wide NKX; 1.5NKC, NKC, AKX, 2 or 3 in. TKC; 12 in. wide noncomposite Sec. 12; 17 in. wide 21; 26 or 28 in. wide UKX, 87.5 cm wide. Side joints of QL, 99, 121, WKX, TKX, TKC, and Metric units — QL-77-900; QLC-78-900; may be welded together 60 in. OC. Side joints of 99, AKX, WKX, GKX, GKX-A, TKX and Metric units — QL-77-900 and QLC-78-900 may be fastened together with min 1 in. long No. 12x14 self-drilling, self-tapping steel screws 36 in. OC.

HAMBRO STRUCTURAL SYSTEMS, DIV OF CANAM STEEL CORP — 36 in. wide, 1-1/2 in. Type P3615HB. The max superimposed loadings for Type P3615HB units shall not exceed 250 PSF. For single spans, the use of the units shall be limited to 5 ft. 6 in., 6 ft 0 in. and 6 ft 6 in. max spans for the 22, 20 and 18 gauge units, respectively. For multiple spans, 18 gauge units may be used on a max 7 ft 6 in. span with a max total superimposed loading of 240 PSF.

INTSEL STEEL EAST LLC — 36 in. wide Types 1.5" COMPOSITE/FLOOR, 2" COMPOSITE/FLOOR, 3" COMPOSITE/FLOOR.

KAM INDUSTRIES LTD, DBA CORDECK — 24 in. wide Types 2 or 3 in. WDR.

MARLYN STEEL DECKS INC — Type 1.5 CF, 2.0 CF or 3.0 CF.

NEW MILLENNIUM BUILDING SYSTEMS L L C — 24 or 36 in. wide Types 2.0CD, 3.0CD, 2.0CFD, 3.0CFD, 3.0CFDES; 24, 30 or 36 in. wide Types 1.5CD, 1.5CDI, 1.5CDR, 1.5CFD. Fluted units may be uncoated, phos/painted or galvanized.

STEEL MASTERS INTERNATIONAL DEPENDABLE STEEL — 36 in. wide Types 2WH-36, 3WH-36. Units may be phos/painted or galvanized.

VALLEY JOIST+DECK — 24 or 36 in. wide Types WVC 1-1/2 or WVC 2.



VERCO DECKING INC - A NUCOR CO — FORMLOK™ deck types PLB, B, BR, PLN3, N3, PLN, N, PLW2, W2, PLW3, W3. Units may be galvanized, phos./ptd, or mill finish. Units may be cellular or acoustical cellular, with the suffix "CD" or "CD-AC" added to the product name, respectively. All non-cellular deck may be vented or non-vented. 12 in. wide PLW2, W2, PLW3 or W3 units may be blended with 24 or 36 in. wide PLW2, W2, PLW3 or W3 units, respectively; or Types N3, PLN3, N3-CD, PLN3-CD.

VULCRAFT, DIV OF NUCOR CORP — 24, 30 or 36 in. wide, Type 1.5 VL, 1.5 VLI, 1.5PLVLI, 1.5 VLP, 1.5PLVLP; 24 or 36 in. wide. Types 2VLI, 2.0PLVLI, 2VLP, 2.0PLVLP, 3VLI, 3.0PLVLI, 3 VLP, 3.0PLVLP. 36 in. wide Types 1.5 SB, 1.5 SBR; 24 or 36 in wide Types 2.0 SB, 3.0 SB, 36 in. wide Type High Strength 1.5 SBI, 36 in. wide Type High Strength 1.5 SBN.

Components for field-assembled cellular metal raceway units:

Raceway Bottom — 24 or 36 in. wide Types 212 VS, 312 VS .

Raceway Cover Plate — Types CP-12, CP-16.

Raceway Divider — Type DC-20, DC-25.

Raceway Isolation Trough — Types T-20, T-25, T-30.

Spacing of welds attaching units to supports shall be 12 in. OC for 12, 24 and 36 in. wide units, four welds per sheet for 30 in. wide units, 6 in. OC for 18 in. wide and Sec. 12 units. Unless noted otherwise, adjacent units button-punched or welded together 36 in. OC alongside joints. Adjacent 18 in. wide units welded together 30 in. OC alongside joints. For 3 Hr Rating, units with overlapping type side joints welded together 24 in. OC max.

The Unrestrained Assembly Rating is equal to the Unrestrained Beam Rating for a max of 3 Hr and is limited to the following floor units and spans:

(a) 1-1/2, 2 and 3 in. deep, 24 in. wide, 22 MSG or thicker fluted with clear spans not more than 7 ft, 8 in.

(b) 1-1/2, 2 and 3 in. deep, 24 in. wide, 20 MSG or thicker fluted with clear spans not more than 8 ft, 8 in.

(c) 1-1/2 and 2 in. deep, 24 in. wide, 16 MSG or thicker fluted and 18/18 MSG or thicker cellular with clear spans not more than 9 ft, 11 in.

(d) 3 in. deep, 36 in. wide, 18 MSG or thicker fluted and 24 in. wide, 20/18 MSG or thicker cellular with clear spans not more than 13 ft, 2 in.

For assemblies utilizing 3-1/4 in. lightweight concrete topping with a max Restrained Assembly Rating of 2 Hr, the Unrestrained Assembly Rating is equal to the Unrestrained Beam Rating and is limited to the following floor units and spans:

(a) 1-1/2, 2, and 3 in. deep, 24 or 36 in. wide, 22 MSG fluted and 20/20 MSG cellular with clear spans not more than 9 ft, 6 in.

(b) 2 and 3 in. deep, 24 or 36 in. wide 20 MSG fluted and 20/20 MSG cellular with clear spans not more than 10 ft, 0 in.

(c) 3 in. deep, 24 in. wide, 20 MSG fluted and 20/20 MSG cellular with clear spans not more than 13 ft, 2 in.

3A. Steel Floor and Form Units* — (not Shown) - As an alternate to Item 3. Nom 8 or 9 in. deep composite, galv steel units. Min thickness 0.0375 inch (20 MSG). Side joints of adjacent units fully overlapping, fastened together by using 1-1/4 in. long self-drilling, self-tapping steel screws driven through Shear-Bond Clips (not shown) at 13-3/4 in. OC. Steel end closures flashings (not shown) made of min 0.056 inch thick (16 MSG) galv steel, fixed to the steel work before decking is placed.

In addition to the Steel Floor and Form Units, the following components are required:

(a) Welded Wire Fabric — 6 X 6 - Min wire thickness W2.9 X W2.9 slab reinforcement. As an alternate, max # 4 bars spaced 12-in. OC in both directions shall be used. When re-bars are used, the concrete slab thickness shall be increased a minimum 5/16 in.

(b) Rib Reinforcement — Min. #4 rebar. Min concrete cover below the steel reinforcement shall be 1-9/16 in. Reinforcement support chairs spaced at max 41-1/2 inches OC.

The flute areas above the beam/joist are to be : (1) filled with concrete, (2) filled with Spray-Applied Fire Resistive Material or (3) the beam/joist coated with Spray-Applied Fire Resistive Material installed as described in the design to thickness required when all cellular Steel Floor and Form Units are used.

See Design No. D989 for a typical illustration of the components. Consult the deck manufacturer for comprehensive load tables and design parameters referencing UL Design D989.

BAILEY METAL PRODUCTS LTD — Type COMSLAB™ 210 and COMSLAB™ 225, Steel End Closure Flashing

4. Spray-Applied Fire Resistive Materials — Applied by mixing with water and spraying in one or more coats to a final thickness as shown in the tables below, to steel beam surfaces which must be clean and free of dirt, loose scale and oil. Min avg and min ind density of 15/14 pcf, respectively for Types MK-6/HY, MK-6/HY Extended Set, MK-6/HB, MK-6s, MK-6 GF, MK-6 GF Extended Set, MK-10 HB, MK-10 HB Extended Set, MK-1000/HB, MK-1000/HB Extended Set, RG. Min avg and min ind density of 22/19, respectively for Types Z-106, Z-106/G, Z-106/HY. Min avg and min ind density of 50/45 pcf respectively for Types AV800, Z-156, Z-156T and Z-156PC.



For method of density determination, refer to Design Information Section.

Restrained Assembly Rating Hr	Unrestrained Assembly Rating Hr	Unrestrained Beam Rating Hr	W8x28 Beam (see Note #1 and #2)	W8x28 Beam Supporting (see Note #1 and #2)	
				All Fluted Floor Units w/Light weight Concrete	Fluted Floor Units and Normal Weight Concrete Only
1	1	1	1/2	5/16	5/16
1-1/2	1	1	1/2	5/16	5/16
1-1/2	1-1/2	1-1/2	13/16	5/8	9/16
2	1	1	1/2	5/16	5/16
2	2	2	1-3/16	7/8	11/16
3	1-1/2	1-1/2	13/16	5/8	9/16
3	3	3	2	1-5/16	1-5/16
3	3	4	2-13/16	1-5/8	1-7/8

Note #1: Restrained or unrestrained joists from the N series designs may be substituted for the listed beam. When joists are substituted, the restrained rating of the joist must be equal to or greater than the restrained rating of the assembly. Additional joist substitution requirements are contained in the front of the Fire Resistance Directory.

Note # 2: Restrained or unrestrained beams from the N series designs may be substituted for the listed beam. When beams are substituted, the restrained rating of the beam must be equal to or greater than the restrained rating of the assembly. Additional beam substitution requirements are contained in the front of the Fire Resistance Directory.

The thicknesses of Spray-Applied Fire Resistive Materials shown in the table below are applicable when the thickness applied to the beams' lower flange edges is reduced to one-half that shown in the table.

Restrained Assembly Rating Hr	Unrestrained Assembly Rating Hr	Unrestrained Beam Rating Hr	W8x28 Beam	W8x28 Beam Supporting All Fluted Floor Units w/Lightweight Concrete	W8x28 Beam Supporting All Fluted Floor Units w/ Normal weight Concrete
1	1	1	11/16	7/16+	3/8+
1-1/2	1	1	11/16	7/16+	3/8+
1-1/2	1-1/2	1-1/2	1	3/4	5/8
2	1	1	11/16	7/16+	3/8+
2	2	2	1-3/8	1	13/16
3	1-1/2	1-1/2	1	3/4	5/8

3	3	3	2-3/16	1-7/16	1-3/8
3	3	4	3	1-15/16	1-15/16

+Thickness applied to beams' lower flange edges shall be a minimum of 1/4 in.

ARABIAN VERMICULITE INDUSTRIES — Types MK-6/HY, MK-6/HY Extended Set, MK-6/HB, MK-6s, MK-6 GF, MK-6 GF Extended Set, MK-10 HB, MK-10 HB Extended Set, MK-1000/HB, MK-1000/HB Extended Set, Z-106, Z-106/G, Z-106/HY, AV800, Z-156, Z-156T and Z-156PC

GCP KOREA INC — Types MK-6/HY, MK-6/HY Extended Set, MK-6/HB, MK-6s, MK-6 GF, MK-6 GF Extended Set, MK-10 HB, MK-10 HB Extended Set, MK-1000/HB, MK-1000/HB Extended Set, Z-106/G, Z-106, Z-106/HY, and Z-146.

GCP APPLIED TECHNOLOGIES INC — Types MK-6/HY, MK-6/HY Extended Set, MK-6/HB, MK-6s, MK-6 GF, MK-6 GF Extended Set, MK-10 HB, MK-10 HB Extended Set, MK-1000/HB, MK-1000/HB Extended Set, RG, Z-106/G, Z-106, Z-106/HY, Z-146, Z-146PC, Z-146T, Z-156, Z-156T and Z-156PC.

4A. **Sprayed Fiber*** — (Optional, Not Shown) Sprayed Fiber, Classified for Surface Burning Characteristics (BNST), having a maximum applied density of 3.5 pcf applied over both Steel Floor and Form Units (Item 3 and 3A) and over Spray-Applied Fire Resistive Material (Item 4 through 4B) on Supports. Sprayed Fiber may be applied to the underside of Steel Floor and Form Units (Item 3 and 3A) at an unlimited thickness. Sprayed Fiber may be applied over Spray-Applied Fire Resistive Material (Item 4 through 4B) on Supports according to the following table:

Allowable Sprayed Fiber Thickness over SFRM applied to Beams

Installed SFRM Thickness (in.) on Beam	SFRM Density (lb/ft ³)			
	15	22	40	50
5/16	8	8	8	8
7/16	8	8	8	8
1/2	8	8	8	8
9/16	8	8	8	8
5/8	8	8	8	8
11/16	8	8	8	8
3/4	8	8	8	8
13/16	8	8	8	8
7/8	8	8	8	8
1	8	8	8	8
1-1/16	8	8	8	8
1-1/8	8	8	8	8
1-3/16	8	8	8	8
1-5/16	7-3/4	8	8	8
1-3/8	7-1/2	8	8	8
1-7/16	7-1/4	8	8	8
1-9/16	6-11/16	8	8	8



1-5/8	6-7/16	8	7-7/8	8
1-3/4	5-7/8	8	6-7/16	8
1-13/16	5-5/8	8	5-11/16	7-1/8
2	4-13/16	7-1/16	3-9/16	4-7/16
2-1/16	4-9/16	6-11/16	2-7/8	3-9/16
2-1/8	4-5/16	6-5/16	2-1/8	2-11/16
2-3/16	4	5-7/8	1-7/16	1-13/16
2-5/16	3-1/2	5-1/8	0	0
2-3/8	3-3/16	4-11/16	0	0
2-11/16	1-14/16	2-12/16	0	0
2-3/4	1-10/16	2-6/16	0	0
3-1/8	0	0	0	0

INTERNATIONAL CELLULOSE CORP — Type K13, URE-K, or SonaSpray FC

4B. **Sprayed Fiber*** — (Optional, Not Shown) Sprayed Fiber, Classified for Surface Burning Characteristics (BNST), having a maximum applied density of 2.8 pcf applied over both Steel Floor and Form Units (Item 3 and 3A) and over Spray-Applied Fire Resistive Material (Item 4 through 4B) on Supports. Sprayed Fiber may be applied to the underside of Steel Floor and Form Units (Item 3 and 3A) at an unlimited thickness. Sprayed Fiber may be applied over Spray-Applied Fire Resistive Material (Item 4 through 4B) on Supports according to the following table:

Allowable Sprayed Fiber Thickness over SFRM applied to Beams

Installed SFRM Thickness (in.) on Beam	SFRM Density (lb/ft ³)			
	15	22	40	50
Sprayed Fiber Thickness (in.)				
5/16	5	5	5	5
7/16	5	5	5	5
1/2	5	5	5	5
9/16	5	5	5	5
5/8	5	5	5	5
11/16	5	5	5	5
3/4	5	5	5	5
13/16	5	5	5	5
7/8	5	5	5	5
1	5	5	5	5
1-1/16	5	5	5	5

1-1/8	5	5	5	5
1-3/16	5	5	5	5
1-5/16	5	5	5	5
1-3/8	5	5	5	5
1-7/16	5	5	5	5
1-9/16	5	5	5	5
1-5/8	5	5	5	5
1-3/4	5	5	5	5
1-13/16	5	5	5	5
2	5	5	4 7/16	5
2-1/16	5	5	3 9/16	4 7/16
2-1/8	5	5	2 11/16	3 3/8
2-3/16	5	5	1 13/16	2 1/4
2-5/16	4 3/8	5	0	0
2-3/8	4	5	0	0
2-11/16	2 3/8	3 7/16	0	0
2-3/4	2	2 15/16	0	0
3-1/8	0	0	0	0

MONOGLASS INC — Type Monoglass

4C. **Sprayed Fiber*** — (Optional, Not Shown) Sprayed Fiber, Classified for Noncombustible Building Materials (BICW), having a maximum applied density of 3.5 pcf applied over both Steel Floor and Form Units (Item 3 and 3A) and over Spray-Applied Fire Resistive Material (Item 4 through 4B) on Supports. Sprayed Fiber may be applied to the underside of Steel Floor and Form Units (Item 3 and 3A) at an unlimited thickness. Sprayed Fiber may be applied over Spray-Applied Fire Resistive Material (Item 4 through 4B) on Supports according to the following table:

Allowable Sprayed Fiber Thickness over SFRM applied to Beams

Installed SFRM Thickness (in.) on Beam	SFRM Density (lb/ft ³)			
	15	22	40	50
Sprayed Fiber Thickness (in.)				
5/16	5	5	5	5
7/16	5	5	5	5
1/2	5	5	5	5
9/16	5	5	5	5
5/8	5	5	5	5



11/16	5	5	5	5
3/4	5	5	5	5
13/16	5	5	5	5
7/8	5	5	5	5
1	5	5	5	5
1-1/16	5	5	5	5
1-1/8	5	5	5	5
1-3/16	5	5	5	5
1-5/16	5	5	5	5
1-3/8	5	5	5	5
1-7/16	5	5	5	5
1-9/16	5	5	5	5
1-5/8	5	5	5	5
1-3/4	5	5	5	5
1-13/16	5	5	5	5
2	4-13/16	5	3-9/16	4-7/16
2-1/16	4-9/16	5	2-7/8	3-9/16
2-1/8	4-5/16	5	2-1/8	2-11/16
2-3/16	4	5	1-7/16	1-13/16
2-5/16	3-1/2	5	0	0
2-3/8	3-3/16	4-11/16	0	0
2-11/16	1-7/8	2-3/4	0	0
2-3/4	1-5/8	2-3/8	0	0
3-1/8	0	0	0	0

THERMACOUSTIC IND. — Type TC-417

5. **Shear-Connector-Studs-Optional** — Studs 3/4 in. diam by 3 in. long, for 1-1/2 in. deep form units to 5-1/4 in. long for 3 in. deep form units, headed type or equivalent per AISC specifications. Welded to the top flange of the beam through the steel form units.

6. **Electrical Inserts** — (Not shown) Classified as "Outlet Boxes and Fittings Classified for Fire Resistance".

H H ROBERTSON — Preset Inserts.

For use with 2-1/2 in. lightweight concrete topping over QL-WKX steel floor units. Installed over factory-punched holes in floor units per accompanying installation instructions. Spacing shall not be more than one insert in each 14 sq ft of floor area with spacing along floor units not less than 48 in. OC. The holes cut in insert cover for passage of wires shall be no more than 1/8 in. larger diam than wire. Restrained Assembly



Rating is 3/4 hr with Tapmate II-FS-1 and 1 hr with Tapmate II-FS-2 inserts.

H H ROBERTSON — Tapmate II-FS-1, II-FS-2; Series KEB.

WIREMOLD CO — After set Inserts. Single-service after set inserts installed per accompanying installation instructions in 2-1/2 in. diam hole core-drilled through min 3-1/4 in. thick concrete topping to top of cell of any min 3 in. deep cellular steel floor unit specified under Item 3. Spacing shall be no more than one insert in each 10 sq ft of floor area in each span with a min center to center spacing of 16 in. If the high potential and low potential raceways of the cellular steel floor unit are separated by a valley filled with concrete, the center to center spacing of the high potential and low potential single-service after set inserts may be reduced to a min of 7-1/2 in. Restrained Assembly Rating is 2 hr or less with internally protected Type 436 after set insert with Type M4-, M6- or M8- Series single-service activation fitting.

WIREMOLD CO — Internally protected Type 436 after set insert with Type M4-, M6- or M8- Series single-service activation fitting.

7. **Roof Covering Materials*** — (Optional, not shown) Consisting of materials compatible with insulations described herein which provide Class A, B or C coverings. See Roofing Materials and Systems Directory - Roof Covering Materials (TEVT).

8. **Insulating Concrete** — (not shown) Optional. Various types of insulating concrete prepared and applied in the thickness indicated:
A. **Vermiculite Concrete** — (not shown) Optional.

1. Blend 6 to 8 cu ft of Vermiculite Aggregate* to 94 lb Portland Cement and air entraining agent. Min thickness of 2 in. as measured to the top surface of the structural concrete or foamed plastic (Item 9) when it is used.

SIPLAST INC

VERMICULITE PRODUCTS INC

2. Blend 3.5 cu ft. of Type NVC Concrete Aggregate* or Type NVS Vermiculite Aggregate* to 94 lb Portland Cement. Slurry coat, 1/8 in. thickness beneath foamed plastic (Item 9) when used, 1 in. min topping thickness.

SIPLAST INC

VERMICULITE PRODUCTS INC

Vermiculite concrete may be covered with Roof Covering Materials (Item 7).

B. **Cellular Concrete-Roof Topping Mixture*** — Concentrate mixed with water and Portland Cement per manufacturers specifications. Min. thickness of 2-in. as measured to the top surface of the structural concrete or foamed plastic (Item 9) when used. 28-day min compressive strength of 190 psi as determined with ASTM C495-66.

CELCORE INC — Type Celcore with cast dry density of 31 (+ or - 3.0) pcf or Type Celcore MF with cast dry density of 29 (+ or - 3.0) pcf.

AERIX INDUSTRIES — Cast dry density of 37 (+ or -) 3.0 pcf.

ELASTIZELL CORP OF AMERICA — Type II. Mix #1 of cast dry density 39 (+ or -) 3.0 pcf, Mix #2 of cast dry density 40 (+ or -) 3.0 pcf, Mix #3 of cast dry density 47 (+ or -) 3.0 pcf.

SIPLAST INC — Mix No. 1 or 2. Cast dry density of 32+3 (Mix No. 1) or 36+3 (mix No. 2) pcf.

C. **Perlite Concrete** — Mix consists of 6.2 cu ft Perlite Aggregate* to 94 lbs of Portland cement and 1-1/2 pt air entraining agent. Compressive strength 80 psi min.

See Perlite Aggregate (CFFX) category for names of Classified companies.

D. **Cellular Concrete-Roof Topping Mixture*** — Foam Concentrate mixed with water, Portland Cement and UL Classified Vermiculite Aggregate per manufacturer's application instructions. Cast dry density of 33 (+ or -) 3.0 pcf and 28-day compressive strength of min 250 psi as determined in accordance with ASTM C495-86.

AERIX INDUSTRIES — Mix No. 3.

SIPLAST INC — Mix No. 3.



E. **Floor Topping Mixture* (Optional, not shown)** — Approx 4.5 gal of water to 41 lbs of NVS Premix floor topping mixture. Slurry coat 1/8 in. thickness beneath foamed plastic (Item 9) when used, 1 in. min topping thickness.

SIPLAST INC

Floor Topping Mixture may be covered with Built-Up or Single Membrane Roof Covering.

9. **Foamed Plastic*** — (Optional-not shown) For use only with vermiculate or cellular concretes or Floor Topping mixture (Item 8E) - Rigid polystyrene foamed plastic insulation having slots and/or holes sandwiched between vermiculite concrete slurry which is applied to the normal or lightweight concrete surface and concrete topping.

SIPLAST INC

VERMICULITE PRODUCTS INC

10. **Roof Insulation-Mineral and Fiber Boards* or Foamed Plastic*** — (Optional, not shown, Not for use with Item 3A)) — Mineral and fiber boards or polyisocyanurate roof insulation applied over concrete floor with no restriction on board thickness. When mineral and fiber boards or polyisocyanurate roof insulation are used the thickness of Spray-Applied Fire Resistive Materials shown in the table below are applicable when the thickness applied to the beams' lower flange edges is reduced by one-half and the beams are supporting solid concrete slabs or floor assemblies containing only fluted floor or form units with lightweight concrete. The table below is applicable when W8x28 or alternate (per BXUV Category Guide in the front of the Fire Resistance Directory) steel beam is used. See Mineral and Fiber Boards (CERZ) or Foamed Plastic (CCVW) category for names of Manufacturers.

Min Thkns In.

Rating Hr	Restrained Beam	Unrestrained Beam
1	7/16+	3/4
1-1/2	11/16	1
2	15/16	1-1/4
3	1-7/16	1-11/16

+ Thickness applied to beams' lower flange edges shall be a min of 1/4 in.

*** Indicates such products shall bear the UL or cUL Certification Mark for jurisdictions employing the UL or cUL Certification (such as Canada), respectively.**

Last Updated on 2024-08-02

The appearance of a company's name or product in this database does not in itself assure that products so identified have been manufactured under UL Solutions' Follow - Up Service. Only those products bearing the UL Mark should be considered to be Certified and covered under UL Solutions' Follow - Up Service. Always look for the Mark on the product.

UL Solutions permits the reproduction of the material contained in Product iQ subject to the following conditions: 1. The Guide Information, Assemblies, Constructions, Designs, Systems, and/or Certifications (files) must be presented in their entirety and in a non-misleading manner, without any manipulation of the data (or drawings). 2. The statement "Reprinted from Product iQ with permission from UL Solutions" must appear adjacent to the extracted material. In addition, the reprinted material must include a copyright notice in the following format: "©2024 UL LLC."

