

Design/System/Construction/Assembly Usage Disclaimer

- Authorities Having Jurisdiction should be consulted in all cases as to the particular requirements covering the installation and use of UL Certified products, equipment, system, devices, and materials.
- Authorities Having Jurisdiction should be consulted before construction.
- Fire resistance assemblies and products are developed by the design submitter and have been investigated by UL for compliance with applicable requirements. The published information cannot always address every construction nuance encountered in the field.
- When field issues arise, it is recommended the first contact for assistance be the technical service staff provided by the product manufacturer noted for the design. Users of fire resistance assemblies are advised to consult the general Guide Information for each product category and each group of assemblies. The Guide Information includes specifics concerning alternate materials and alternate methods of construction.
- Only products which bear UL's Mark are considered Certified.

BXUV - Fire Resistance Ratings - ANSI/UL 263 Certified for United States

BXUV7 - Fire Resistance Ratings - CAN/ULC-S101 Certified for Canada

[See General Information for Fire-resistance Ratings - ANSI/UL 263 Certified for United States Design Criteria and Allowable Variances](#)

[See General Information for Fire Resistance Ratings - CAN/ULC-S101 Certified for Canada Design Criteria and Allowable Variances](#)

Design No. D780

August 02, 2024

Restrained Assembly Rating — 1, 1-1/2, 2 or 3 h

Unrestrained Assembly Rating — 1, 1-1/2, 2 or 3 h (See Item 5)

Unrestrained Beam Ratings — 1, 1-1/2, 2 or 3 h (See Item 5)

Restricted Load Condition — See Items 4 and 5B

This design was evaluated using a load design method other than the Limit States Design Method (e.g., Working Stress Design Method). For jurisdictions employing the Limit States Design Method, such as Canada, a load restriction factor shall be used — See Guide [BXUV](#) or [BXUV7](#)

*** Indicates such products shall bear the UL or cUL Certification Mark for jurisdictions employing the UL or cUL Certification (such as Canada), respectively.**



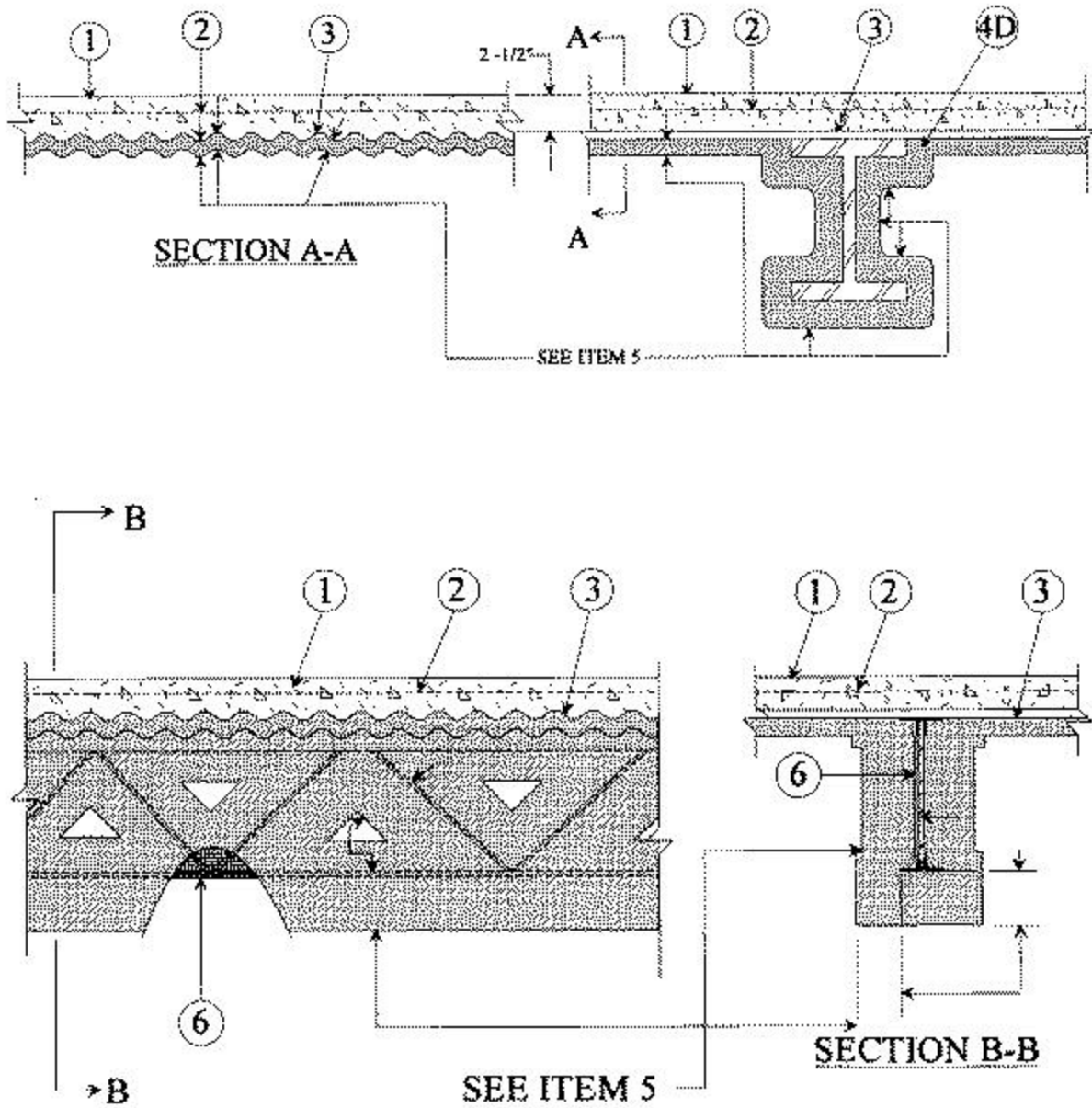

1. **Normal Weight or Lightweight Aggregate Concrete** — Normal weight carbonate or siliceous aggregate concrete, 150 plus over minus 3 pcf unit weight, 3500 psi compressive strength, vibrated. Lightweight concrete, expanded shale, clay, or slate aggregate by rotary-kiln method, 110 plus over minus 3 pcf unit weight, 3500 psi compressive strength, 4 to 7 percent entrapped air.

2. **Welded Wire Fabric** — 6 x 6 — W2.0 X W2.0

3. **Steel Floor and Form Units** — No. 28 MSG galv corrugated sheet steel minimum. The description and sizes of the corrugated sheet steel units and the max beam spacing are as follows:

Steel Deck Unit In.	Nom Pitch In.	Sheet Steel Gauge MSG	Max Beam Spacing
9/16	2-1/2	28	3 ft, 6 in. O.C.
15/16	3-3/4	26	5 ft, 0 in. O.C.
1-5/16	5	26	6 ft, 6 in. O.C.
1-5/16	5	24	7 ft, 0 in. O.C.

1-5/16	5	22	7 ft, 6 in. O.C.
1-5/16	5	20	8 ft, 0 in. O.C.

Units welded to each steel beam, 36 welds per 100 sq ft of form units with at least one weld at each side joint. Welding of deck side joint between beams for deck spans ranging between 3 ft, 6 in. and 6 ft, 6 in. O.C. shall be at least two welds of each side joint. Welding of side joints for spans greater than 6 ft, 6 in. O.C. shall be a minimum of three welds of each side joint.

Any Manufacturer — Corrugated deck having cross-section similar to above description.

3A. Steel Floor and Form Units — As an alternate to Item 3, Composite or non-composite, 1-1/2, 2, or 3 in. deep galv fluted units. Min gauge is No. 22 MSG. Spacing of welds attaching units to supports shall be at each side of joint and not to exceed 12 in. OC between joints. Adjacent units button punched or welded together 36 in. OC at joints.

CANAM GROUP INC — 36 in. wide Type P-3623, P-3606 and P-3615 composite; 24 in. wide Type P-2432 composite; Type 3 in. Lok Floor. Type LF3 unit may be phos/painted or painted/painted; 36 in. wide Types 1.5B, 1.5BI, 1.5BL and 1.5BL; 24 in. or 36 in. wide, Type LF2.

CANAM STEEL CORP — Types B, B Lok, N Lok, 1-1/2, 2 and 3 in. Lok Floor, UFS and UFX. Units may be phos/painted or painted/painted.

VERCO DECKING INC - A NUCOR CO — Types PLB, HSB, PLN3, HSN3, PLN, N, and FORMLOK™ deck types PLB, B, BR, PLN3, N3, PLN, N, PLW2, W2, PLW3, W3. Units are min 24 in. wide and may be galvanized or phos./ptd.

VULCRAFT, DIV OF NUCOR CORP — 24, 30 and 36 in. wide Type 1.5VLI; 24 or 36 in. wide Types 2VLI, 3VLI. Types 1-SLVI, 2VLI, and 3VLI units may be phos/ptd. Type BW Slotted Deck.

4. Steel Joists — 10K1 or 16K2 min size with a max tensile stress of 30,000 psi or 12K3 min size with max tensile stress of 24,000 psi.

4A. As an alternate to Item 4, LH Series joists spanning no greater than 60 ft. For spans greater than 60 ft, deflection under the published total load shall not be greater than 1/277 of the joist span.

4B. Composite Joists — (Not shown) — As an alternate to Items 4 and 4A, steel joists designed for full composite action with the concrete slab. Min overall depth 13 in. Min area of joist members shall be 0.708 square in. for top and bottom chord angles and 0.442 square in. for web. Designed in accordance with SJI Specifications for K-Series joists as revised to November 18, 1989.

4C. Structural Steel Members* — (Not shown) — As an alternate to Items 4, 4A and 4B — (Not shown) — Composite joists with top chord embedded in concrete slab. Welded to end supports. Min area of joist members shall be 0.708 square in. for top and bottom chord angles and 0.442 square in. for web.

VESCOM STRUCTURAL SYSTEMS INC — Type V.

4D. Steel Beams — W8x28 min size. As an alternate to steel joists, Items 4, 4A, 4B and 4C.

4E. Horizontal Bridging — (Not shown) — Min 1-1/4 by 1-1/4 by 1/8 in. thick steel angles for use with noncomposite joists (Item 4). Number and spacing per Steel Joist Institute specifications. Welded to top and bottom chord of the joists. Min thickness of Spray-Applied Fire Resistive Materials on bridging angles is 1-1/2 in.



5. Spray-Applied Fire Resistive Materials* — Applied by mixing with water and spraying in no more than one coat to a final thickness as shown below to steel surfaces which must be free of dirt, loose scale and oil. Min avg and min ind density of 15/14 pcf, respectively. For method of density determination, see Design Information Section, Sprayed Materials.

Restrained Assembly Rating Hr	Unrestrained Assembly Rating Hr	Unrestrained Beam Rating Hr	on Deck	on Beam
1	1	1	3/8	7/16

1-1/2	1	1	1/2	7/16
1-1/2	1-1/2	1-1/2	1/2	3/4
2	1	1	1/2	7/16
2	2	2	5/8	1
3	1-1/2	1-1/2	1/2	3/4
3	3	3	7/8	1-5/16

Rating Hr	Rating Hr	Rating Hr	LH Joist	Joist Thickness			
				10K1		16K2	
				more than 4 ft OC	less than 4 ft OC	more than 4 ft OC	less than 4 ft OC
1	1	1	1-1/8	1-1/8	15/16	15/16	15/16
1-1/2	1	1	1-5/16	1-5/16	1-5/16	1-1/4	1-3/16
1-1/2	1-1/2	1-1/2	1-1/2	1-5/8	1-7/16	1-1/4	1-3/16
2	1	1	1-7/16	1-7/16	1-7/16	1-9/16	1-1/2
2	2	2	1-1/2	2-3/16	1-15/16	1-9/16	1-1/2
3	1-1/2	1-1/2	1-1/2	3-1/4	2-13/16	2-1/4	2-1/8
3	3	3	3-1/4	3-1/4	2-13/16	2-1/4	2-1/8

ARABIAN VERMICULITE INDUSTRIES — Types MK-6/CBF, MK-6/ED, MK-6/HY, MK-6/HY Extended Set, MK-10 HB, MK-10 HB Extended Set, MK-6/HB, MK-6s.

GCP APPLIED TECHNOLOGIES INC — Types MK-6 GF, MK-6/HY, MK-6/HY Extended Set, MK-10 HB, MK-10 HB Extended Set, MK-6/HB, MK-6s, RG .

GCP KOREA INC — Types MK-6/CBF, MK-6/ED, MK-6 GF, MK-6/HY, MK-6/HY Extended Set, MK-10 HB, MK-10 HB Extended Set, MK-6/HB, MK-6s

5A. **Spray-Applied Fire Resistive Materials*** — Applied by mixing with water and spraying in more than one coat to a final thickness as shown below to steel surfaces which must be free of dirt, loose scale and oil. When steel deck is used, the area between the steel deck and the beams top flange shall be filled. Min avg and min ind density of 22/19 pcf, respectively for Types Z-106, Z-106/HY and Z-106/G . Min avg and min ind density of 40/36 pcf, respectively for Z-146. Application to steel deck requires the installation of expanded metal lath with Type Z-146 . See Item 6B. For method of density determination, see Design Information Section, sprayed materials.

Restrained Assembly Rating Hr	Unrestrained Assembly Rating Hr	Unrestrained Beam Rating Hr	on Deck	on Beam
-------------------------------	---------------------------------	-----------------------------	---------	---------

1	1	1	7/16	7/16
1-1/2	1	1	9/16	7/16
1-1/2	1-1/2	1-1/2	9/16	3/4
2	1	1	9/16	7/16
2	2	2	5/8	1
3	1-1/2	1-1/2	9/16	3/4
3	3	3	7/8	1-5/16

Rating Hr	Rating Hr	Rating Hr	LH Joist	Joist Thickness			
				10K1		16K2	
				more than 4 ft OC	less than 4 ft OC	more than 4 ft OC	less than 4 ft OC
1	1	1	1-1/8	1-1/8	15/16	15/16	15/16
1-1/2	1	1	1-5/16	1-5/16	1-5/16	1-1/4	1-3/16
1-1/2	1-1/2	1-1/2	1-1/2	1-5/8	1-7/16	1-1/4	1-3/16
2	1	1	1-7/16	1-7/16	1-7/16	1-9/16	1-1/2
2	2	2	1-1/2	2-3/16	1-15/16	1-9/16	1-1/2
3	1-1/2	1-1/2	1-1/2	3-1/4	2-13/16	2-1/4	2-1/8
3	3	3	3-1/4	3-1/4	2-13/16	2-1/4	2-1/8

ARABIAN VERMICULITE INDUSTRIES — Types Z-106, Z-106/G, Z-106/HY, Z-146 investigated for exterior use.



GCP APPLIED TECHNOLOGIES INC — Types Z-106, Z-106/G, Z-106/HY, Z-146 investigated for exterior use.

GCP KOREA INC — Types Z-106, Z-106/G, Z-106/HY, Z-146 investigated for exterior use.

5B. Alternate Spray-Applied Fire Resistive Materials* — Applied by mixing with water and spraying in more than one coat to final thicknesses as shown in the illustration above and in the table below to steel surfaces which must be clean and free of dirt, loose scale and oil. For minimum and maximum density of: Types MK-6/CBF, MK-6/ED, MK-6 GF, MK-6/HY, MK-6/HY Extended Set, MK-6/HB, MK-6s see Item 5; Z-106, Z-106/G, Z-106/HY, Z-146 see Item 5A.

Joist thickness

Restrained Assembly Rating Hr	Unrestrained Assembly Rating Hr	Unrestrained Beam Rating Hr	12K3** more than 4 ft OC	12K3** less than 4 ft OC
1	1	1	15/16	15/16
1-1/2	1-1/2	1-1/2	1-1/4	1-3/16
2	2	2	1-9/16	1-1/2
3	3	3	2-1/4	2-1/8

**Design load shall stress the 12K3 joist to a maximum tensile strength of 24,000 psi, which represents 80% of the maximum allowable design loading. Based on the Steel Joist Institute (SJI) Publication, "Catalog of Standard Specifications and Load Tables for Steel Joists and Joist Girders" for guidance on how to increase the design loading accordingly.

ARABIAN VERMICULITE INDUSTRIES — Types MK-6/CBF, MK-6/ED, MK-6/HY, MK-6/HY Extended Set, MK-10 HB, MK-10 HB Extended Set, MK-6/HB, MK-6s, Z-106, Z-106/G, Z-106/HY, Z-146 investigated for exterior use.

GCP APPLIED TECHNOLOGIES INC — Types MK-6 GF, MK-6/HY, MK-6/HY Extended Set, MK-10 HB, MK-10 HB Extended Set, MK-6/HB, MK-6s, RG, Z-106, Z-106/G, Z-106/HY, Z-146 investigated for exterior use.

GCP KOREA INC — Types MK-6/CBF, MK-6/ED, MK-6 GF, MK-6/HY, MK-6/HY Extended Set, MK-10 HB, MK-10 HB Extended Set, MK-6/HB, MK-6s, Z-106, Z-106/G, Z-106/HY, Z-146 investigated for exterior use.

6. **Metal Lath** — (Optional) — Metal lath may be used to facilitate the spray application of spray-applied resistive materials to steel bar joists and trusses. The diamond mesh, 3/8 in. expanded steel lath, 1.7 to 3.4 lb per sq yd is secured to one side of each steel joist with No. 18 SWG galv steel wire at joist web and bottom chord members, spaced 15 in. OC max. When used, the metal lath is to be fully covered with spray-applied resistive materials with no min thickness requirements.

6A. **Nonmetallic Fabric Mesh** — (Optional, not shown) — Glass fiber mesh weighing approx 1.25 oz per sq yd, polypropylene fabric mesh, weighing approx 1.25 oz per sq yd or equivalent, may be used to facilitate the spray application. The mesh is secured to one side of each joist web member. The method of attaching the mesh must be sufficient to hold the mesh and the spray-applied resistive materials in place during application until it has cured. An acceptable method to attach the mesh is by embedding the mesh in min 1/4 in. long beads of hot melted glue. The beads of glue shall be spaced a max of 12 in. OC along the top chord of the bar joist. Another method to secure the mesh is by 1-1/4 in. long by 1/2 in. wide hairpin clips formed from No. 18 SWG or heavier steel wire.

6B. **Metal Lath** — (Not shown)— (Required with Z-146, Sonophone 35, and Monokote Acoustic 35, otherwise optional) — Metal lath shall be 3/8 in. expanded diamond mesh, weighing 2.5 lb per sq yd. Secured to underside of steel deck with No. 12 by 3/8 in. pan head self-drilling, self-tapping screws and steel washers with an outside diam of 1/2 in. screws spaced 12 in. OC in both directions with lath edges overlapped approx 3 in.

7. **Shear Connector — Studs — Optional** — (Not shown) — Studs 3/4 in. diameter by 3 in. long headed type or equivalent per AISI specifications. Welded to the top flange of beam through the steel form units.



*** Indicates such products shall bear the UL or cUL Certification Mark for jurisdictions employing the UL or cUL Certification (such as Canada), respectively.**

Last Updated on 2024-08-02

The appearance of a company's name or product in this database does not in itself assure that products so identified have been manufactured under UL Solutions' Follow - Up Service. Only those products bearing the UL Mark should be considered to be Certified and covered under UL Solutions' Follow - Up Service. Always look for the Mark on the product.

UL Solutions permits the reproduction of the material contained in Product iQ subject to the following conditions: 1. The Guide Information, Assemblies, Constructions, Designs, Systems, and/or Certifications (files) must be presented in their entirety and in a non-misleading manner, without any manipulation of the data (or drawings). 2. The statement "Reprinted from Product iQ with permission from UL Solutions" must appear adjacent to the extracted material. In addition, the reprinted material must include a copyright notice in the following format: "©2024 UL LLC."

