



BXUV.N852

Design/System/Construction/Assembly Usage Disclaimer

- Authorities Having Jurisdiction should be consulted in all cases as to the particular requirements covering the installation and use of UL Certified products, equipment, system, devices, and materials.
- Authorities Having Jurisdiction should be consulted before construction.
- Fire resistance assemblies and products are developed by the design submitter and have been investigated by UL for compliance with applicable requirements. The published information cannot always address every construction nuance encountered in the field.
- When field issues arise, it is recommended the first contact for assistance be the technical service staff provided by the product manufacturer noted for the design. Users of fire resistance assemblies are advised to consult the general Guide Information for each product category and each group of assemblies. The Guide Information includes specifics concerning alternate materials and alternate methods of construction.
- Only products which bear UL's Mark are considered Certified.

BXUV - Fire Resistance Ratings - ANSI/UL 263 Certified for United States

BXUV7 - Fire Resistance Ratings - CAN/ULC-S101 Certified for Canada

Design No. N852

Restrained Beam Ratings — 1, 1-1/2, 2, 3 and 4 Hr

Unrestrained Beam Ratings — 1, 1-1/2, 2, 3 and 4 Hr

Loading Determined by Allowable Stress Design Method or Load and Resistance Factor Design Method published by the American Institute of Steel Construction, or in accordance with the relevant Limit State Design provisions of Part 4 of the National Building Code of Canada

*** Indicates such products shall bear the UL or cUL Certification Mark for jurisdictions employing the UL or cUL Certification (such as Canada), respectively.**

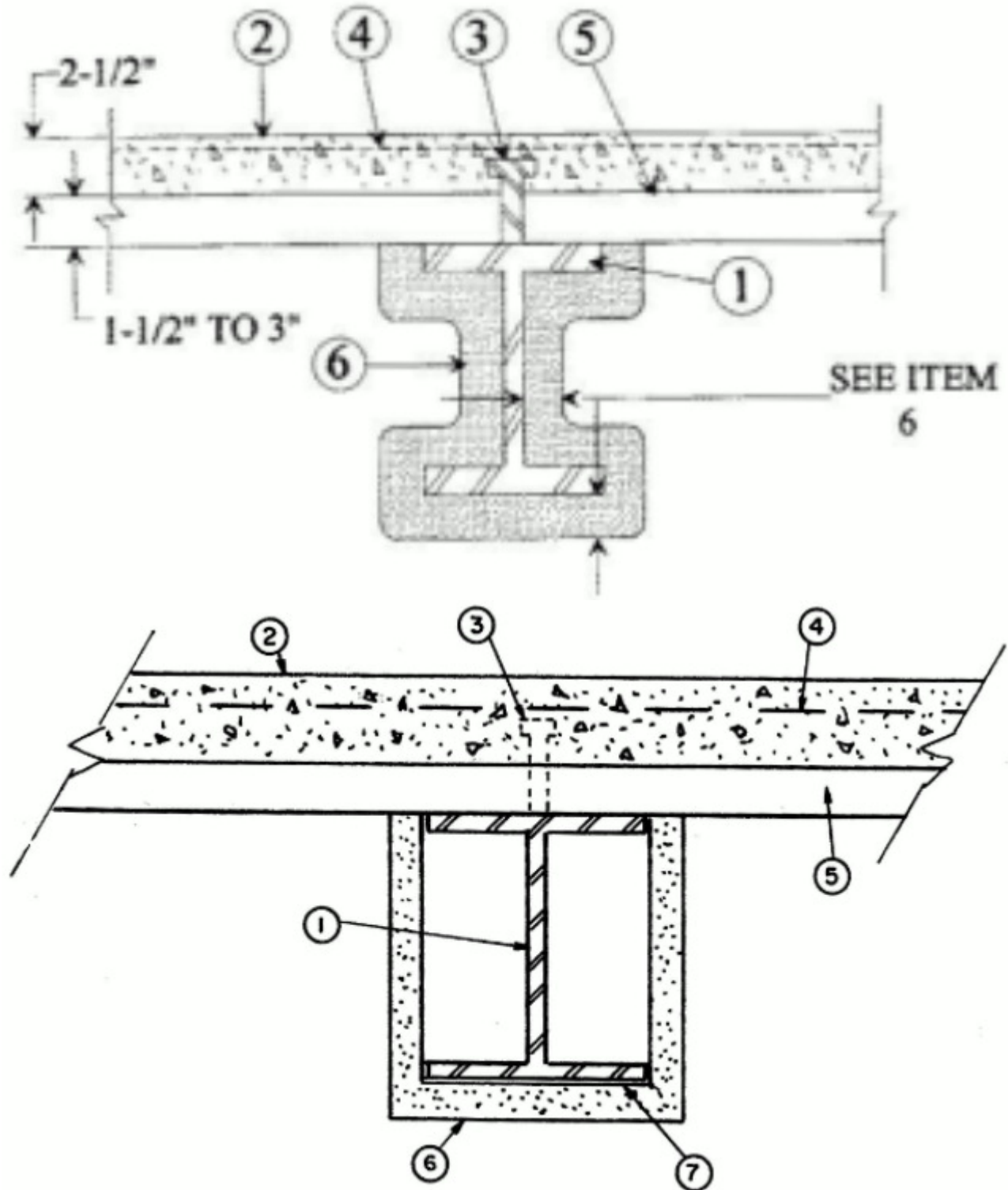

1. **Steel Beam** — W8x28 min size.

2. **Normal Weight Concrete** — Compressive strength, 4000 psi. Either carbonate or siliceous aggregate may be used. Unit weight, 145 +/- 3 pcf.

2A. **Light Weight Concrete** — Compressive strength, 3000 psi. Either expanded shale, clay or slate aggregate by rotary-kiln method. Unit weight, 110 +/- 3 pcf.

3. **Shear Connector** — (Optional) — Studs, 3/4 in. diam headed type or equivalent per AISC specifications. Welded to the top flange of beam through the steel floor units.

4. **Welded Wire Fabric** — (Optional) — 6x6-10/10 SWG.

5. **Steel Floor and Form Units*** — 1-5/16 in. deep corrugated units; or 1-1/2 to 3 in. deep fluted or cellular units welded to beam.

6. **Spray-Applied Fire Resistive Materials*** — Applied by mixing with water and spraying in more than one coat to the beam to the final thicknesses shown below. Crest areas shall be filled with Spray-Applied Fire Resistive Materials above the beam. Beam surfaces must be clean and free of dirt, loose scale and oil. Min average and min ind. density of 15/14 pcf respectively. Min avg and min ind density of 22/19 pcf respectively for Types Z-106, Z-106/HY, Z-106/G. Min avg and min ind density of 40/36 pcf respectively for Types AV650, Z-146, Z-146PC and Z-146T cementitious mixture. Min avg and min ind density of 50/45 pcf respectively for Types AV800, Z-156, Z-156T and Z-156PC. For method of density determination, see Design Information Section.

The thickness of Spray-Applied Fire Resistive Materials shown in the table below are only applicable when the beams are supporting floor assemblies containing only fluted floor and form units, topped with normal weight concrete (Item 2).

Rating Hr	Min Thkns In.	
	Restrained Beam	Unrestrained Beam
1	5/16	5/16
1-1/2	7/16	9/16
2	11/16	13/16
2(+)	9/16	11/16
3	1-3/16	1-5/16
3(+)	15/16	1-5/16
4	1-11/16	1-7/8

(+) Rating applicable only when a minimum of 4-1/2 in. of normal weight concrete provided over deck crests.

The thickness of Spray-Applied Fire Resistive Materials shown in the table below are only applicable when the beams are supporting floor assemblies containing corrugated or cellular floor and form units, topped with normal weight concrete (Item 2).

Rating Hr	Min Thkns In.	
	Restrained Beam	Unrestrained Beam
1	3/8	3/8
1-1/2	9/16	11/16
2	7/8	1-1/16
2(+)	3/4	15/16
3	1-9/16	1-11/16
3(#)	1-7/16	1-9/16
4	2-1/4	2-7/16

(+) Rating applicable only when a minimum of 4-1/2 in. of normal weight concrete provided over deck crests.

(#) Rating applicable only when a minimum of 5-1/4 in. of normal weight concrete provide over deck crests.

The thickness of Spray-Applied Fire Resistive Materials shown in the table below are applicable when the thickness applied to the beams' lower flange edges is reduced by one-half and the beams are supporting solid concrete slabs or floor assemblies containing only fluted floor or form units with normal weight concrete (Item 2).

Rating Hr

Min Thkns In.

	Restrained Beam	Unrestrained Beam
1	3/8	3/8
1-1/2	7/16	5/8
2	11/16	7/8
2(+)	9/16	13/16
3	1-3/16	1-7/16
3(#)	1-1/16	1-3/8
4	1-11/16	1-15/16

(+) Rating applicable only when a minimum of 4-1/2 in. of normal weight concrete provided over deck crests.

(#) Rating applicable only when a minimum of 5-1/4 in. of normal weight concrete provide over deck crests.

The thickness of Spray-Applied Fire Resistive Materials shown in the table below are applicable when the thickness applied to the beams' lower flange edges is reduced by one-half and the beams are supporting solid concrete slabs or floor assemblies containing corrugated or cellular floor or form units with normal weight concrete (Item 2).

	Min Thkns In.	
Rating Hr	Restrained Beam	Unrestrained Beam
1	1/2	1/2
1-1/2	9/16	13/16
2	7/8	1-1/8
2(+)	3/4	1-1/16
3	1-9/16	1-7/8
3(#)	1-7/16	1-13/16
4	2-1/4	2-9/16

(+) Rating applicable only when a minimum of 4-1/2 in. of normal weight concrete provided over deck crests.

(#) Rating applicable only when a minimum of 5-1/4 in. of normal weight concrete provide over deck crests.

The thickness of Spray-Applied Fire Resistive Materials shown in the table below are only applicable when the beams are supporting floor assemblies containing only fluted floor and form units, topped with light weight concrete (Item 2A).

	Min Thkns In.	
Rating Hr	Restrained Beam	Unrestrained Beam
1	3/8	3/8
1-1/2	8/16	5/8
2	13/16	15/16
2 (+)	13/16	7/8
3	1-5/16	1-9/16
3 (+)	1-5/16	1-5/16

4	1-7/8	2-1/8
---	-------	-------

(+) Rating applicable only when a minimum of 3-1/4 in. of light weight concrete provided over deck crests.

The thickness of Spray-Applied Fire Resistive Materials shown in the table below are only applicable when the beams are supporting floor assemblies containing cellular or corrugated floor and form units, topped with light weight concrete (Item 2A).

Min Thkns In.

Rating Hr	Restrained Beam	Unrestrained Beam
1	1/2	1/2
1-1/2	5/8	13/16
2	1-1/16	1-3/16
3	1-11/16	2
4	2-7/16	2-13/16

The thickness of Spray-Applied Fire Resistive Materials shown in the table below are applicable when the thickness applied to the beams' lower flange edges is reduced by one-half and the beams are supporting solid concrete slabs or floor assemblies containing only fluted floor or form units with light weight concrete (Item 2A).

Min Thkns In.

Rating Hr	Restrained Beam	Unrestrained Beam
1	1/2	1/2
1-1/2	9/16	3/4
2	7/8	1-1/16
3	1-3/8	1-11/16
4	1-15/16	2-1/4

The thickness of Spray-Applied Fire Resistive Materials shown in the table below are applicable when the thickness applied to the beams' lower flange edges is reduced by one-half and the beams are supporting solid concrete slabs or floor assemblies containing corrugated or cellular floor or form units with light weight concrete (Item 2A).

Min Thkns In.

Rating Hr	Restrained Beam	Unrestrained Beam
1	5/8	11/16
1-1/2	11/16	1
2	1-1/8	1-3/8
3	1-3/4	2-3/16
4	2-1/2	3

ARABIAN Vermiculite Industries — Types MK-6/HY, MK-6/HY Extended Set, MK-10 HB, MK-10 HB Extended Set, MK-6/HB, MK-6s, MK-6 GF, MK-6 GF Extended Set, MK-1000/HB, MK-1000/HB Extended Set, Z-106, Z-106/G, Z-146 investigated for exterior use. Types AV650 and AV800 investigated for external use.

GCP KOREA INC — Types MK-6/HY, MK-6/HY Extended Set, MK-10 HB, MK-10 HB Extended Set, MK-6/HB, MK-6s, MK-6 GF, MK-6 GF Extended Set, MK-1000/HB, MK-1000/HB Extended Set, Z-106, Z-106/G, Z-106/HY, Z-146 investigated for exterior use.

GCP APPLIED TECHNOLOGIES INC — Types MK-6/HY, MK-6/HY Extended Set, MK-10 HB, MK-10 HB Extended Set, MK-6/HB, MK-6s, MK-6 GF, MK-6 GF Extended Set, MK-1000/HB, MK-1000/HB Extended Set, RG, Z-106, Z-106/G, Z-106/HY, Z-146, Z-146T, Z146PC, Z-156, Z-156T and Z-156PC investigated for exterior use.

7. **Metal Lath** — (Optional for contour applications, required for boxed applications) — 3.4 lb/sq yd expanded steel. May be tied to lath hangers with No. 18 SWG steel wire spaced 6 in. OC max. or fastened directly to the steel with welds, screws, or powder actuated fasteners.

*** Indicates such products shall bear the UL or cUL Certification Mark for jurisdictions employing the UL or cUL Certification (such as Canada), respectively.**

Last Updated on 2021-05-10

The appearance of a company's name or product in this database does not in itself assure that products so identified have been manufactured under UL's Follow-Up Service. Only those products bearing the UL Mark should be considered to be Certified and covered under UL's Follow-Up Service. Always look for the Mark on the product.

UL permits the reproduction of the material contained in the Online Certification Directory subject to the following conditions: 1. The Guide Information, Assemblies, Constructions, Designs, Systems, and/or Certifications (files) must be presented in their entirety and in a non-misleading manner, without any manipulation of the data (or drawings). 2. The statement "Reprinted from the Online Certifications Directory with permission from UL" must appear adjacent to the extracted material. In addition, the reprinted material must include a copyright notice in the following format: "© 2021 UL LLC"